

CADD[®]

**CADD[®]-Solis VIP
Ambulatory Infusion Pump**

Operator's Manual

Model 2120

Software version 1.6

smiths medical



The CADD®-Solis VIP (variable infusion profile) Ambulatory Infusion Pump is designed to promote patient care and safety for a variety of adult and pediatric patients, and clinical care areas.

This manual describes only the CADD®-Solis VIP Ambulatory Infusion Pump, software version 1.6 and higher, CADD®-Solis VIP Pump with PharmGuard® Medication Safety Software Enabled protocol libraries configuration, CADD®-Solis VIP Pump with Select Protocols configuration, and CADD®-Solis VIP Pump with Standard Settings configuration. See table below for three configurations offered with different functionality enabled through software. Smiths Medical recommends that you maintain the same software version across all CADD®-Solis VIP pumps in your facility. Refer to the PharmGuard® Administrator Medication Safety Software installation guide and online help for information specific to that program.

This pump can be programmed with a pump protocol configuration consisting of a therapy, qualifier, and drug. The pump can deliver medication via patient controlled analgesia (PCA), continuous, intermittent, variable stepped rate, and tapered infusions.

This manual is intended for use by clinicians and system administrators only. Do not permit patients to have access to it. The pump has three security levels designed to limit overall access to certain pump features. Disclose the pump security codes only to those who are authorized. Access to the pump key should also be restricted.

The issue date of this Operator’s Manual is included on the back cover. In the event one year has elapsed between the issue date and product use, contact Smiths Medical to see if an updated version is available.

PHARMGUARD®	SELECT	STANDARD
<ul style="list-style-type: none"> • Efficient Manual Programming of each infusion • Factory Library pre-loaded on the pump with additional safety limits • PharmGuard® Software Enabled to download custom drug libraries to the pump 	<ul style="list-style-type: none"> • Efficient Manual Programming of each infusion • Factory Library pre-loaded on the pump with additional safety limits 	<ul style="list-style-type: none"> • Efficient manual programming of each infusion • No drug library implementation
 <p>REAR LABELS</p>		
 <p>POWER UP SCREENS</p>		

Technical Assistance

If you have comments or questions concerning the operation of the CADD[®]-Solis VIP Ambulatory Infusion Pump, call the number given below. When calling, specify the pump software version number. This information is located in the device information report (See *Device Information* on page 102 for more information).

Smiths Medical is available to help with the programming and operation of the CADD[®]-Solis VIP Ambulatory Infusion Pump.

U.S. Distribution:

Smiths Medical ASD, Inc.
6000 Nathan Lane North
Minneapolis, MN 55442 USA
Tel: 1 800 258 5361 (US/CA)
Tel: +1 614 210 7300

European Distribution:

Smiths Medical Czech Republic a. s.
Olomoucká 306, Hranice 1 - Město,
753 01 Hranice, Czech Republic
Tel: +44 (0)1233 722100

www.smiths-medical.com

Read this entire operator's manual before operating the CADD[®]-Solis VIP ambulatory infusion pump. Failure to properly follow warnings, cautions, and instructions could result in death or serious injury to the patient.

Contraindications

- The pump is not to be used for delivery of blood or cellular blood products, as blood and cellular blood products will be damaged by the pumping mechanism.
- This pump is not to be used in any intra-articular space infusion.

Warnings

- This operator's manual should be used by authorized clinicians and system administrators only. Do not permit patients to have access to this manual, as the information contained allows complete access to all programming and operating functions.
- To avoid explosion hazard, do not use the pump in the presence of flammable anesthetics or explosive gases.
- For patients likely to be adversely affected by unintended operations and failures, including interrupted medication or fluid delivery from the device, close supervision and provision for immediate corrective action should be provided in order to assure minimum medication delivery interruption. Pump failure suspends medication delivery, and unintended pump operations could lead to a variety of consequences for the patient.
- If the pump is used to deliver life-sustaining medication, an additional pump must be available, and close supervision and provision for immediate corrective action should be provided to assure minimum medication delivery interruption in the event of a pump failure. Pump failure suspends medication delivery.
- The user should ensure that the performance offered by the pump is fit for the intended use and that the pump is not used in any way or for any purpose other than its intended use.
- If the pump is dropped or hit, inspect it for damage. Do not use a pump that is damaged or not functioning properly. Contact Smiths Medical Customer Service to return a pump for service.
- To avoid patient injury and electric shock, remove the pump from patient prior to any preventative maintenance and servicing of the pump.

-
- Do not use a syringe with the CADD®-Solis pump. The use of a syringe could result in underdelivery of medication.
 - The CADD®-Solis VIP pump and accessories include small component pieces that could pose a choking hazard to young children.
 - Do not administer drugs to the epidural space or subarachnoid space unless the drug is indicated for administration to those spaces.
 - To prevent the infusion of drugs that are not indicated for epidural space or subarachnoid space infusion, DO NOT use administration sets that incorporate injection sites.
 - If a CADD™ medication cassette reservoir, CADD® extension set, or CADD® administration set is used for epidural space or subarachnoid space drug delivery, it is strongly recommended that it be clearly differentiated from those used for other routes of infusion (for example, by color coding or other means of identification).
 - If the air detector is turned off, the pump does not detect air in the fluid path. It is recommended that you periodically inspect the fluid path and remove any air to prevent air embolism.
 - The air detector, when turned on, may be set to detect and alarm for air bubbles as small as 150 uL. The High Sensitivity setting and/or filtered sets should be considered for patients and therapies with a risk of harm due to an air embolism.
 - When the upstream occlusion sensor is turned off, the pump does not detect occlusions upstream between the pump and the reservoir. Periodic inspection of the fluid path for kinks, a closed clamp, or other upstream obstructions is recommended. Upstream occlusions may result in underdelivery of medication.
 - Do not disclose pump security codes or any other information that would allow the patient or unauthorized clinician complete access to programming and operating functions.
 - Do not leave the pump unattended while unlocked. All programming functions are accessible while the pump is unlocked.
 - The manual program mode does not contain programming limits. Carefully review each parameter to ensure it accurately matches the prescription.
 - Always carefully review the program on the pump after it has been programmed to verify that the pump is programmed correctly.
 - The remote dose cord is for *patient use only*. Operation by anyone other than the patient may cause overdelivery of medication.
 - Ensure that the $\pm 6\%$ system delivery accuracy specification is taken into account when programming the pump and/or filling the reservoir. Failure to do so may result in medication in the reservoir becoming depleted sooner than expected.
 - Exercise care when using the clinician bolus function. Because there are no limits to the frequency of delivering a bolus, and because the bolus amount may be set as high as 50 mL (or the mg or mcg equivalent), you should not permit the patient or unauthorized clinician to become familiar with the procedure for giving a clinician bolus.
 - To prevent the patient from accessing the clinician bolus function, do not let the patient know the clinician or administrator security codes.
 - Never leave the pump unattended while on the clinician bolus edit screen. You must deliver the programmed value, or cancel and leave the screen.
 - Do not use rechargeable NiCd or nickel metal hydride (NiMH) batteries. Do not use carbon zinc (“heavy duty”) batteries. They do not provide sufficient power for the pump to operate properly.
 - Always have new batteries available for replacement. If power is lost, nondelivery of drug occurs.
 - A rechargeable battery pack that has reached the end of its useful life must be replaced with either another CADD®-Solis rechargeable battery pack or with 4 AA batteries.

-
- There is no pump alarm to alert users that a battery has not been properly installed. An improperly installed battery could result in loss of power and nondelivery of drug.
 - A hazard can exist if different alarm styles are used on multiple pumps in the same single care area; for example, a critical care area or operating room. Auditory alarm signal sound levels that are less than ambient levels can hinder operator recognition of alarm conditions.
 - A hazard can exist if a user depends on audible alarm indications without a corresponding visual indication. Use of low volume alarm settings or distance from the device can hinder operator recognition of alarm conditions when hearing impairment may be a concern, or when the clinician may be away from the device.
 - Always check the battery compartment for fluid or debris before inserting the batteries, and do not allow any fluid or debris to fall into the battery compartment. Fluid or debris in the battery compartment may damage the battery contacts and could result in loss of power and nondelivery of drug.
 - If the pump is dropped or hit, the battery door may become broken or damaged. Do not use the pump if the battery door is damaged because the batteries will not be properly secured. This may result in loss of power and non-delivery of drug.
 - Follow the instructions for use provided with the CADD™ medication cassette reservoir, CADD® extension set, or CADD® administration set, paying particular attention to all warnings and cautions associated with their use.
 - Carefully route tubing, cords, and cables to reduce the possibility of patient entanglement or strangulation.
 - Per general rules of safe practice, always clamp the tubing before removing the cassette from the pump. Removing the cassette without closing the clamp could potentially cause unregulated gravity infusion.
 - Attach the cassette properly. A detached or improperly attached cassette could result in unregulated gravity infusion of medication from the reservoir or a reflux of blood.

If you are using a CADD® administration set or CADD™ medication cassette reservoir that does not have the Flow Stop feature, you must use a CADD® extension set with anti-siphon valve, or a CADD® administration set with either an integral or add-on anti-siphon valve to protect against unregulated gravity infusion that can result from an improperly attached cassette.

- Do not prime the fluid path with the tubing connected to a patient as this could result in overdosing of medication or air embolism.
- To prevent air embolism, ensure that the entire fluid path is free of all air bubbles before connecting to the patient.
- Ensure that debris is not allowed to build up on the pressure plate surface of the pumping mechanism. Inspect the air detector sensor slot and remove any debris. A blocked air detector sensor may not detect air present in the fluid path.
- CADD® pumps have been designed and validated for use with the CADD™ Medication Cassette Reservoirs and other CADD® tubing sets manufactured by Smiths Medical. Use of non-Smiths Medical manufactured tubing sets will affect the functional performance of the system and will void the pump warranty.
- System delivery inaccuracies beyond $\pm 6\%$ may occur as a result of back pressure or fluid resistance, which depends upon temperature, drug viscosity, catheter size, extension set tubing (for example, microbore), in-line components (such as filters and needleless access connectors), and placing the infusion reservoir and/or pump above or below the level of the patient. System delivery inaccuracy may result in under or overdosing of medication.
- The use of power supplies and a remote dose cord other than those listed in the electromagnetic emissions declaration may result in increased emissions or decreased immunity of the pump.
- Serious harm to the patient or operator may result from the use of modified parts or parts not authorized by Smiths Medical. Do not modify the system, parts, or accessories.

-
- The pump should not be used adjacent to or stacked with other equipment. If adjacent or stacked use is necessary, verify normal operation of the pump in the configuration in which it is to be used.
 - Common portable and mobile consumer electronic devices may cause interference with the pump. Observe the pump to verify normal operation. If abnormal performance is observed, it may be necessary to reorient or relocate the pump away from radio frequency transmitting devices.
 - To avoid electric shock, do not touch the Power Jack, Remote Dose Cord Jack, USB Port, Battery Terminals, or any other connectors and the patient simultaneously.
 - Residential/facility wiring must comply with all applicable electrical codes. Do not bypass power cord connections. Do not remove a prong from the power cord.
 - There are potential health hazards associated with improper disposal of batteries, electronics, and contaminated (used) reservoirs and extension sets. Dispose of used batteries, reservoirs, extension sets, and other used accessories, or a pump that has reached the end of its useful life, in an environmentally safe manner, and according to any regulations that may apply.
 - Always set the Delivery Limit amount alarm, Reservoir Volume Low alarm, and all other variable alarm settings to clinically appropriate settings. Setting alarm limits to values not clinically safe for the patient may cause patient harm due to a delay in therapy.
 - To avoid any potential electrical interference or delivery inaccuracies, power off the pump when the pump is being transported in an aircraft.

Cautions

- Do not operate the pump at temperatures below 2°C (36°F) or above 40°C (104°F) to avoid damaging the electronic circuitry.
- Do not store the pump at temperatures below -20°C (-4°F) or above 60°C (140°F) to avoid damaging the electronic circuitry. Do not store the pump with a CADD™ medication cassette reservoir or CADD® administration set attached.
- If the pump is stored outside of the environmental operating conditions and within the specified environmental storage conditions, allow the pump to warm or cool to operating temperature for at least one hour prior to use to avoid damaging the electronic circuitry.
- Do not expose the pump to humidity levels below 20% or above 90% relative humidity to avoid damaging the electronic circuitry.
- CADD® pumps are sealed units. A broken or damaged seal will therefore be considered conclusive evidence that the pump has been misused and/or altered, which voids any and all warranties. All service and repair of CADD® pumps must be performed by Smiths Medical or its authorized agents.
- Use only Smiths Medical accessories that are specified for use with the CADD®-Solis ambulatory infusion pump, as other brands may adversely affect pump operation.
- Inspect the AA batteries for damage or wear to the metal or plastic insulation prior to use, or after the pump has been dropped or hit. Replace the batteries if any damage is noted.
- Do not store the pump for prolonged periods with the batteries installed. Battery leakage could damage the pump.
- If the power up results in an error message indicating that the protocol library was lost, do not proceed with using the pump. Follow your facility's procedures for downloading protocol libraries.
- If you are using a CADD™ medication cassette reservoir in which the medication is frozen, thaw at room temperature only. Do not heat in a microwave oven as this may damage the product and cause leakage.
- If delivery of an infusion is affected by a time or date change, an alarm message appears and must be confirmed.
- Do not immerse the pump in cleaning fluid or water. Do not allow solution to soak into the pump, accumulate on the keypad, or enter the battery compartment, USB port, remote dose cord jack, or power jack areas. Moisture buildup inside the pump may damage the pump.
- Do not clean the pump with acetone, other plastic solvents, or abrasive cleaners, as damage to the pump may occur.
- The pump should *not* be directly irradiated by therapeutic levels of ionizing radiation due to the risk of permanent damage to the electronic circuitry. The best procedure to follow is to remove the pump from the patient during therapeutic radiation sessions or diagnostic levels of radiographic and fluoroscopic radiation. If the pump must remain in the vicinity during a diagnostic or therapy session, it should be shielded, and its ability to function properly should be confirmed following treatment.
- Do not expose the pump directly to ultrasound, as permanent damage to the electronic circuitry may occur.
- Magnetic fields produced by magnetic resonance imaging (MRI) equipment may adversely affect the operation of the pump. Remove the pump from the patient during MRI procedures and keep it at a safe distance from magnetic energy. Exposing the pump to magnetic fields that exceed the 600 gauss line may cause irreversible damage, rendering the pump inoperable.
- Use of this pump on patients monitored by electronic equipment may cause artifactual interference. As with all electronic equipment, electrical artifacts which affect the performance of other equipment, such as ECG monitors, can occur. The user should check the correct function of the equipment prior to use.
- Do not use the pump in hyperbaric chambers as they affect how the pump works and may also cause damage to the pump.

Table of Contents

Technical Assistance	3
Contraindications	3
Warnings	3
Cautions	7

General Description

Introduction	10
Indications	10
Contraindications	10
Epidural/Subarachnoid Administration	10
Analgesics	10
Anesthetics	10
Symbols	11
Pump Diagram	13
Pump Components, Ports, and Connectors ...	14
Indicator Lights	14
Display with Backlighting	14
Keypad	14
Power Switch	15
Power Jack	15
USB Port	15
Remote Dose Cord Jack	15
Battery Compartment	15
Cassette Latch	15
Cassette/Keypad Lock	15
Air Detector	15
Downstream Occlusion Sensor	15
Upstream Occlusion Sensor	15
Accessories	16
PharmGuard® Administrator Medication	
Safety Software	16
AC Adapter	16
Rechargeable Battery Pack	16
Remote Dose Cord	16
Polemount Bracket	16
Polemount Bracket Adapter	16
Polemount Swivel	17
Pump Key	17
Pouches and Backpacks	17
Cassette, Extension Set, Administration Set	17
Pump Screens and Display	18
Pump Screens	18
Using Color	19
Therapy Screen Colors	19
Pump Status Colors	20
Pump Back Label Colors	20
Security Settings	20
Security Level Tables	20
Autolock	23
Entering Security Codes	23
Customized Security Settings	24
Keypad Security	25
Keypad Code	25
Clinician Code	26
Administrator Code	26

Manual Programming	27
--------------------------	----

Pump Programming

Quick Access to Manual Programming	28
Protocols and Protocol Libraries	28
New Protocol Selection	28
Single Protocol Download (for	
PharmGuard® Software Enabled pumps)	28
New Protocol Selection from a Library	
or Manual Mode	29
Start New Patient	29
Start New Protocol Same Patient	29
Manually Programmed Protocols	30
Delayed Start/Next Dose Start Time	33
Delayed Start	33
Next Dose Start Time	34
Delivery Hard and Soft Limits	35
Delivery Settings	36
Editing Delivery Settings	37
Review Pump Settings	38
PCA Delivery Mode	39
Home Screen	39
Programming Screens	40
Programming Example	42
Give a Clinician Bolus	45
Start a PCA Dose	47
Stopping a Clinician Bolus or PCA Dose ...	48
Continuous Delivery Mode	49
Home Screen	49
Programming Screens	49
Programming Example	50
Intermittent Delivery Mode	53
Home Screen	53
Programming Screens	54
Programming Example	55
Stopping the Pump During an Infusion ...	60
Step Delivery Mode	61
Home Screen	61
Programming Screens	62
Programming Example	64
Starting Each infusion	69
Stopping and Restarting the Pump	
During an Infusion	69
Step Up	69
Step Down	70
Taper Delivery Mode	71
Home Screen	71
Programming Screens	72
Programming Example	74
Starting Daily Infusion	78
Stopping and Restarting the Pump	
During an Infusion	79
Taper Down Now	79
Operating the Pump	
Batteries	80
Install the Batteries or Battery Pack	81

Replace the Battery Door	81
Power Up	82
Cassettes	83
Remove a Cassette	83
Attach a Cassette	84
Prime Tubing	86
Prime Tubing After Changing a Cassette ..	86
Prime Tubing, No Cassette Change	87
Start the Pump	88
Stop the Pump	89
Reset Reservoir Volume	90

Tasks and Advanced Tasks

Tasks Menu Overview	91
Display and Sound Settings	92
Backlight Intensity	92
Alarm Volume	92
Sound Theme	93
Key Beep On/Off	94
Numeric Format	94
Time and Date	95
Current Time	95
Current Date	96
Time Format	96
Date Format	97
Daylight Saving Time	97
Reports	98
Total Given	98
Given and PCA Dose Counters	99
PCA Dose Graph	99
Delivery History and Pie Chart	100
Delivery Log	100
Event Log	101
Protocol Library Summary	101
Device Information	102
Advanced Tasks Menu Overview	102
Patient Permissions	103
Priming Security On/Off	104
Delayed Start Security On/Off	104
Air and Occlusion Settings	105
Air Detector On/Off	105
Air Detector Sensitivity	106
Upstream Sensor On/Off	106
Downstream Sensor Sensitivity	107
Alarm Settings	108
Infusion Alerts On/Off	108
Pump Stopped Alarm Type	108
Reservoir Low Trip Point	109
Reservoir Low Alarm Type	109
Reservoir Empty Alarm Type	110
PM Reminder On/Off	110
PM Reminder	111
PM Interval	111
Reset to Factory Settings	112

References and Troubleshooting

Alarms and Messages	113
---------------------------	-----

Types of Alarms	113
System Fault Alarm	113
High Priority Alarm	113
Medium Priority Alarm	113
Low Priority Alarm	114
Multiple Alarms	114
Informational Message and Signals ..	114
Alarm Algorithms	114
Alarm Help Screens	114
User Position	115
Troubleshooting	116
Alarms and Messages, Alphabetical List ..	116
Cleaning and Disinfecting the Pump and Accessories	123
Radiation and Magnetic Resonance Imaging (MRI)	124
Standards used in development of the pump ..	124
Medical Electrical Equipment	124
Electromagnetic Compatibility	125
Miscellaneous Standards	125
Essential Performance	125
PCA Delivery Mode Scroll Ranges	126
Military Time	127
Specifications (Nominal)	128
General Pump Specifications	128
Configurable Specifications	136
General Specifications	136
PCA Delivery Specifications	137
Continuous Delivery Specifications ..	137
Intermittent Delivery Specifications ..	137
Step Delivery Specifications	138
Taper Delivery Specifications	138
Electromagnetic Emissions and Immunity Declarations	139
Collect Separately	141
Menu Maps	142
Tasks Menus	142
Advanced Tasks Menus	144
Default Factory Settings	145
Manual Mode Initial Settings	146
Accuracy Test Results	148
Limited Warranty	151

Index

General Description

Introduction

The CADD[®]-Solis VIP ambulatory infusion pump provides measured drug therapy to patients in hospital or outpatient settings. Therapy should always be overseen by a physician or a certified, licensed healthcare professional. As appropriate, the caregiver and patient should be instructed in using the pump.

Indications

The CADD[®]-Solis VIP ambulatory infusion pump is indicated for intravenous, intra-arterial, subcutaneous, intraperitoneal, perineural, surgical site, epidural space, or subarachnoid space infusion.

- **PCA** (patient-controlled analgesia) delivery is used for therapies that require a continuous rate of infusion, patient-controlled demand doses, or both, such as patient-controlled analgesia.
- **Continuous** delivery allows the infusion of drug/fluid at a constant, programmed rate.
- **Intermittent** delivery allows the infusion of a specific volume of drug/fluid at a regular, programmed interval.
- **Step** delivery allows an incremental increase in infusion rate to a specified maximum infusion rate for a specified total infusion volume.
- **Taper** delivery allows a plateau rate of infusion with the option of tapering at the beginning and/or end, and has a programmable KVO rate at the end of the infusion.

Contraindications

- The pump is not to be used for delivery of blood or cellular blood products, as blood and cellular blood products will be damaged by the pumping mechanism.
- This pump is not to be used in any intra-articular space infusion.

Epidural/Subarachnoid Administration

The selected drug must be used in accordance with the indications included in the package insert accompanying the drug. Administration of any drug by this pump is limited by any warnings, precautions, or contraindications in the drug labeling.

Smiths Medical has performed neurotoxicological testing using 0.9% saline to represent aqueous drugs infused into epidural and subarachnoid spaces.

WARNING:

- **Do not administer drugs to the epidural space or subarachnoid space unless the drug is indicated for administration to those spaces. Drugs not intended for epidural or subarachnoid space infusion could result in serious patient injury or death.**
 - **To prevent the infusion of drugs that are not indicated for epidural space or subarachnoid space infusion, DO NOT use administration sets that incorporate injection sites. The inadvertent use of injection sites for infusion of such drugs may cause serious patient injury or death.**
 - **If a CADD™ medication cassette reservoir, CADD[®] extension set, or CADD[®] administration set is used for epidural space or subarachnoid space drug delivery, it is strongly recommended that it be clearly differentiated from those used for other routes of infusion (for example, by color coding or other means of identification). Drugs not intended for epidural or subarachnoid space infusion could result in serious patient injury or death.**
-













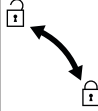















Analgesics

Administration of analgesics to the epidural space is limited to use with indwelling catheters specifically indicated for either short-term or long-term drug delivery.



































Anesthetics

Administration of anesthetics to the epidural space is limited to use with indwelling catheters specifically indicated for short-term drug delivery.

Symbols

Symbols on the Pump and Labels			
	Caution		Power on/off switch
	Refer to Instruction Manual (The symbol appears on the device with a blue background.)		Cassette unlock/lock
	Catalog number		Soft key
	Serial number		Up button
	Date of manufacture		Down button
	Caution: Federal (USA) law restricts this device to sale by or on the order of a physician.		Select button
	Temperature limitation		Stop/Start button
	Humidity limitation		PCA Dose button
	Atmospheric pressure limitation		AA battery location, positive terminal faces up
	Type CF equipment		AA battery location, negative terminal faces up
	Class II equipment		AA battery location, positive terminal faces up
	Solid Particulate Protection: Protected from solid foreign objects greater than 12.5 millimeters in diameter. Liquid Ingress Protection: Splashproof—water splashed against the pump housing will have no harmful effects.		AA battery location, negative terminal faces up
	Collect separately		USB port
	MR Unsafe		Direct current (power jack)
	Authorized Representative in the European Community		Remote dose cord jack

Symbols on the Pump Display

	Reservoir volume		PCA delivery mode
	Charge level of rechargeable battery pack		Continuous delivery mode
	Charge level of rechargeable battery pack. AC adapter connected.		Intermittent delivery mode
	Charge level of AA batteries		Step delivery mode
	Charge level of AA batteries. AC adapter connected.		Taper delivery mode
	No battery installed, AC power only		Keypad is locked
	Incompatible battery		Keypad is unlocked
	Incompatible battery. AC Adapter connected.		Appears next to a parameter that has been reviewed and accepted.
	Pump status is Started or Running.		On edit screens. Indicates current parameter value. Press  or  to scroll up or down to edit the value.
	Pump status is Paused.		On edit screens with a menu of options. Indicates which setting is being selected.
	Pump status is Stopped.		The requested action can not be performed.
	There are more items to see in the work area. Press  or  to scroll up or down.		More data is available. On PCA dose report only.
	Item highlighted in the work area is at the top of the menu. Press  to scroll down.		Review screen
	Item highlighted in the work area is at the bottom of the menu. Press  to scroll up.		Saving

Pump Diagram

Front View

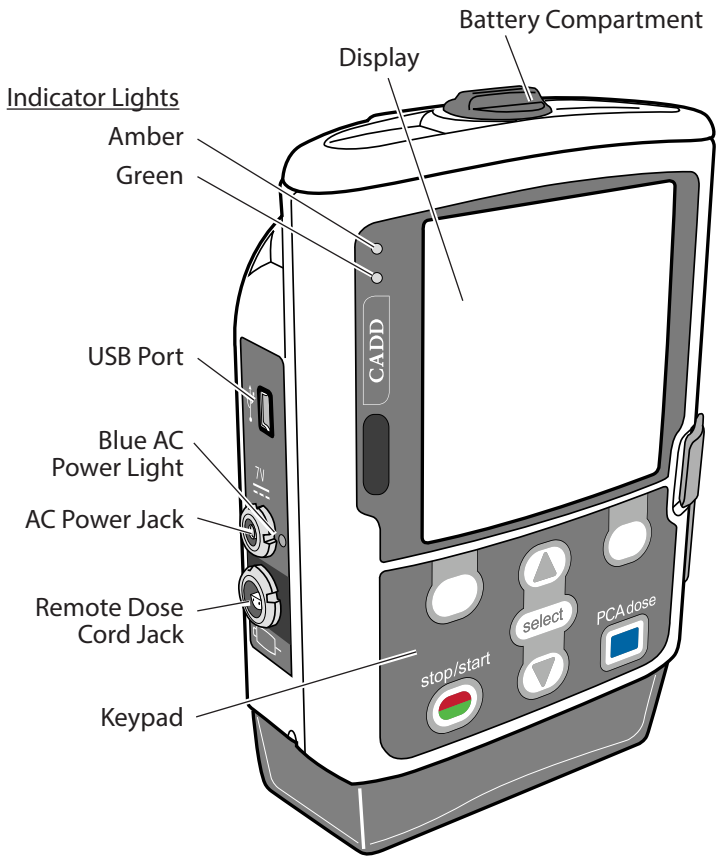

Rear View



Pump Components, Ports, and Connectors

Indicator Lights

When the pump is powered, one or both of the indicator lights flash.

Green: The green light flashes to indicate that the pump is running and delivering fluid as programmed.

Amber: The amber light flashes when the pump is stopped, an alarm condition exists, or the battery or the reservoir volume is low. It stays on continuously when the pump is inoperable. The display briefly describes the alarm condition when the amber light is flashing.



Note: At times both lights may flash. This indicates that the pump is running, but there is a condition that needs attention (for example, low battery or low reservoir volume).

Display with Backlighting

The liquid crystal display (LCD) shows programming information and messages. Backlighting helps keep the display visible in low light. In this manual, “display” is synonymous with display panel or LCD.

After a period of time in which no keys are pressed, the backlighting turns off and the display goes blank to save battery power (except during an alarm or when the AC adapter is in use). To turn the display back on, press any key except the PCA dose key when in PCA mode.

Note:

- When the display is blank, you can determine that the pump is powered by observing either the green or amber (or both) indicator lights periodically flashing.
- If you press stop/start , the display reappears with a message asking if you wish to start or stop the pump.
- If you press PCA dose  while the pump screen is blank, the pump delivers a PCA dose, if that option is available.

Keypad

The keys on the keypad are described below. A key beeps when pressed if it is operable in the current state of the pump. However, the keys do not beep if the key beep function has been turned off in the protocol or the administrator settings.

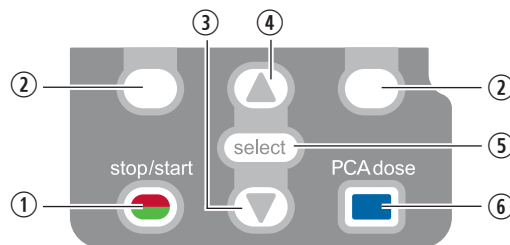

- ① Starts and stops pump delivery.
- ② Referred to as “soft keys.” Allow you to answer a question on the pump’s display. For example, the screen above this key may display “Yes,” in which case pressing this key gives the question displayed on the screen an answer of “Yes.” Also allows you to navigate through some of the pump screens (for example, canceling an action, or backing out of an open screen).
- ③ Allows navigation through the menus on the pump, scrolling down, or decreasing a value.
- ④ Allows navigation through the menus on the pump, scrolling up, or increasing a value.
- ⑤ Used to select a menu item.
- ⑥ Allows the patient to request a PCA dose if the remote dose cord is not connected, and if the PCA dose option is available. If the remote dose cord is connected, this key is inactive.

WARNING: To avoid electric shock, do not touch the Power Jack, Remote Dose Cord Jack, USB Port, Battery Terminals, or any other connectors and the patient simultaneously.

Power Switch

Turns the pump on or off. Press and hold the switch to turn the pump on. Press the switch to turn the pump off, and confirm that you want to power down by selecting **Yes**.

Power Jack

You may plug the AC adapter into the power jack. When the AC adapter is plugged in, the blue power light turns on. This light is on regardless of the pump's on or off status. See *AC Adapter* on page 16 for more information.

USB Port

A mini-B USB cord may be attached to the USB port for communication with the PharmGuard® Administrator Medication Safety Software.

CAUTION: The USB port is intended for communication to the PharmGuard® Medication Safety Software and SureLink® Remote Support Software only. Do not connect unsupported accessories to the USB port (e.g., charging other devices, attaching a wireless dongle) as this could damage the pump.

Remote Dose Cord Jack

Used for attaching the remote dose cord. See *Remote Dose Cord* on page 16 for more information.

Battery Compartment

Four AA batteries or the rechargeable battery pack fit into this compartment. The batteries serve as the primary source of power, or as a backup when the AC adapter is in use. See *Batteries* on page 80 for additional information.

Cassette Latch

Used to attach the cassette to the pump. When the pump is turned on, it detects whether the cassette is latched properly. Delivery stops and an alarm occurs if the cassette becomes unlatched. See *Attach a Cassette* on page 84 and *Remove a Cassette* on page 83.

Cassette/Keypad Lock

Secures the cassette to the pump using the pump key provided. The cassette latch must be latched before it can be locked. The cassette/keypad lock can be configured to unlock only the cassette latch or to unlock the cassette latch as well as the keypad. This is configured by the CADD®-Solis system administrator. See *Security Settings* on page 20.

Air Detector

The air detector may be turned on or off, depending on facility or therapy requirements (see *Air Detector On/Off* on page 105). If air is detected in the part of the tubing that passes the air detector sensor, an alarm sounds and delivery stops. If an air detector is not required, it may be turned off.

WARNING:

- If the air detector is turned off, the pump does not detect air in the fluid path. It is recommended that you periodically inspect the fluid path and remove any air to prevent air embolism, which could result in serious patient injury or death.
 - The air detector, when turned on, may be set to detect and alarm for air bubbles as small as 150 uL. The High Sensitivity setting and/or filtered sets should be considered for patients and therapies with a risk of harm due to an air embolism.
-
-

Downstream Occlusion Sensor

The pump contains a downstream occlusion sensor. When a downstream occlusion (between the pump and the patient) is detected, an alarm sounds, delivery stops, and the display shows “Downstream occlusion. Clear occlusion between pump and patient.”

Upstream Occlusion Sensor

The pump contains an upstream occlusion sensor. This feature may be turned on or off (see *Upstream Sensor On/Off*, on page 106). When an upstream occlusion (between the pump and the reservoir) is

detected, an alarm sounds, delivery stops, and the display shows “Upstream occlusion. Clear occlusion between pump and reservoir.”

WARNING: When the upstream occlusion sensor is turned off, the pump does not detect occlusions upstream between the pump and the reservoir. Periodic inspection of the fluid path for kinks, a closed clamp, or other upstream obstructions is recommended. Upstream occlusions may result in underdelivery of medication. If undetected, these occlusions could lead to death or serious injury to the patient.

Accessories

CAUTION: Use only Smiths Medical accessories that are specified for use with the CADD[®]-Solis ambulatory infusion pump, as other brands may adversely affect pump operations.

All CADD[®]-Solis accessories may be obtained through the Customer Service department at Smiths Medical. For detailed instructions and warnings applicable to each accessory, refer to the instructions for use provided with the product. The Pump Diagram on page 13 illustrates the location of ports, jacks, latches, and compartments used with the accessories.

PharmGuard[®] Administrator Medication Safety Software

The PharmGuard[®] Administrator Medication Safety Software allows you to create and manage protocol libraries and then send them to the pump. See the installation guide and online help for more information.

AC Adapter

The AC adapter can be used as an alternate source of power for the pump and/or to recharge the rechargeable battery pack. The pump requires 4 AA batteries or the rechargeable battery pack to be installed as a backup while using the AC adapter.



Access to the AC adapter power cords should not be blocked at the AC adapter and at the pump connector so they can be easily disconnected.

CAUTION: Discontinue use of the AC Adapter if it is damaged, dropped, if wires become exposed, or if the connector pins are bent or damaged in any way. The use of a damaged AC Adapter could result in electric shock and/or damage to the pump which may cause an interruption or delay of therapy.

If a damaged AC Adapter is connected to a pump, any one or more of the following can occur:

- The pump will not power on
 - The pump screen will remain dark
 - The blue light on the side of the pump near the AC Adapter connector may blink
 - No audible or visible alarm will occur
-

Rechargeable Battery Pack

The rechargeable battery pack is an alternative to using 4 AA batteries. The rechargeable battery pack can be recharged with the AC adapter, either inside or outside of the pump.



Remote Dose Cord

The remote dose cord can be attached to the pump and provided to the patient as an alternative to pushing the PCA dose  key to request a PCA dose.



Polemount Bracket

The polemount bracket is used along with the polemount bracket adapter to attach the pump to an IV pole.

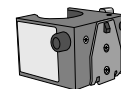

Polemount Bracket Adapter

The polemount bracket adapter attaches to the back of the pump so that it can be mounted on an IV pole or in a LockBox.

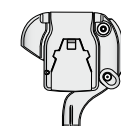

Polemount Swivel

The polemount swivel allows the pump to rotate while it is attached to the CADD®-Solis polemount bracket. With the swivel attached, the pump can be tilted or rotated 230° for easy viewing of the display. The swivel can not be used in a LockBox.

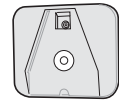

Pump Key

The pump key is used to securely lock a cassette to the pump. It can also be used to lock and unlock the keypad, if allowed by the protocol setting.



Pouches and Backpacks

Several styles of pump pouches and backpacks are available. They can carry a CADD®-Solis ambulatory infusion pump with either a CADD™ medication cassette reservoir (50 mL to 250 mL) or a flexible, plastic IV bag up to 3 liters.

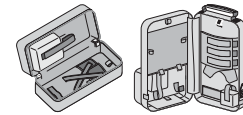

Cassette, Extension Set, Administration Set

The cassette is the part of the CADD™ medication cassette reservoir or CADD® administration set that attaches to the bottom of the pump. The following single-use products are compatible with the pump:

- CADD™ medication cassette reservoir with a CADD® extension set
- CADD® administration set
- CADD® high volume administration set

Using Smiths Medical pouches specifically designed for CADD cassettes and administration sets will help to prevent kinking or undue strain on the tubing. Using non-approved pouches or other accessories may result in adverse effects to the patient and will void your product warranty.

Note: When using a CADD® administration set it is important to provide strain relief to the specific tubing locations identified in the illustration below.

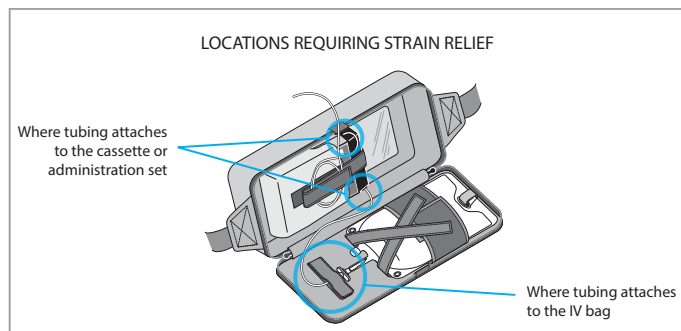

WARNING:

- Follow the instructions for use provided with the CADD™ medication cassette reservoir, CADD® extension set, or CADD® administration set, paying particular attention to all warnings and cautions associated with their use. Incorrect preparation and/or use of these products could result in serious patient injury or death.
 - Carefully route tubing, cords, and cables to reduce the possibility of patient entanglement or strangulation. Failure to observe this warning could result in patient injury or death.
-

Note:

- A CADD® set with free-flow protection must be used in order to prevent free-flow.
- The maximum delivery rate is 500 mL/hr, however, programmed delivery rates exceeding 250 mL/hr require the use of a high volume administration set. Do not manually adjust the delivery rate to override pump programming without written authorization from the prescribing physician.
- Smiths Medical recommends that the appropriate supplies needed to replace the cassettes are available in case of a damaged cassette.
- For detailed instructions and warnings pertaining to the CADD™ medication cassette reservoir or CADD® administration set, refer to the instructions for use supplied with the product for preparing the product for use.

Pump Screens and Display

Pump Screens

The sample screens in this manual are only examples of what might be displayed. The protocols, consisting of therapies, qualifiers, drugs and concentrations, and all associated pump settings in the pump library will be established by your facility.

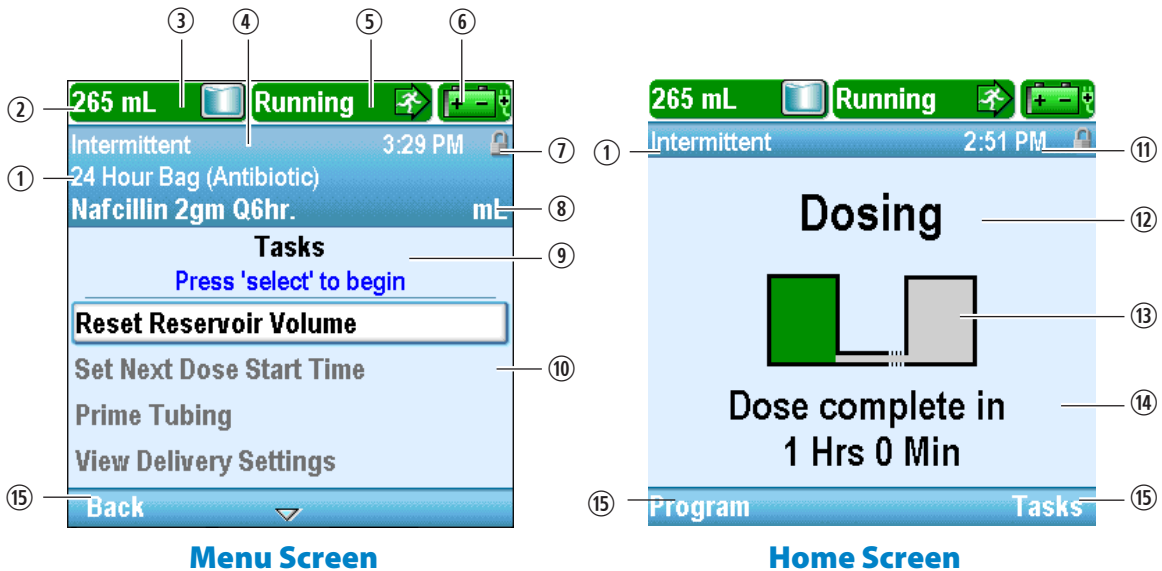

- ① The therapy, qualifier, and drug in the current protocol. On a home screen, only the therapy is listed.
- ② The status bar shows the status of the pump. It may also display messages and alerts.
- ③ Current reservoir volume.
- ④ The screen color is unique for each therapy.
- ⑤ Delivery status of the pump—stopped, running, or paused.
- ⑥ The type of battery in use and the approximate amount of life remaining. Also indicates if an AC adapter is in use.



AA batteries.
Fully charged.



AA batteries
with
AC adapter.
~50% charge.



Rechargeable
battery.
Low battery,
<25% charge.



Rechargeable
battery with
AC adapter.
Depleted battery.

- ⑦ Keypad lock status—locked or unlocked.
- ⑧ Units of measurement and concentration (if applicable) for the drug or solution used in the current protocol.
- ⑨ Screen name and help text, if there is any.
- ⑩ The work area/contents for the displayed screen.
- ⑪ The current time.
- ⑫ The current status of the programmed infusion.
- ⑬ Graphic that identifies which therapy is programmed, and the status of the infusion. See explanations of the different home screens and graphics in *Delivery Settings* beginning on page 36.

- ⑭ Information indicating upcoming events that are important to the user. The message is mode-specific, and *if the pump is running*, indicates one of the following:
- When a delayed start will begin
 - When the reservoir will be empty
 - The current rate of delivery
 - When the next dose will begin



Programming Screen

- When the dose or infusion will be complete

If a new patient or new infusion is programmed but *the pump has not been started*, the message states that the infusion (or dose) will begin when the pump starts.

- ⑮ Options for navigating the pump. These options change depending on the screen and the functions being performed with the pump.
- ⑯ TALL/short characters improve readability to avoid dosing errors.
- ⑰ Trailing zeros are eliminated to avoid dosing errors.

Using Color

Therapy Screen Colors

The pump display uses color to help you recognize critical information quickly and easily. The unique screen color for each type of therapy is factory-set:

Therapy	Screen Color
PCA	Purple*
Continuous	Gray
Intermittent	Blue
Step	Olive
Taper	Green

* May be customized to yellow.

For PCA therapy only, the screen color may be changed to yellow by using the PharmGuard® Administrator Medication Safety Software. Depending on the needs of your pain management program, your facility may choose to relate a purple or yellow screen to a specific protocol, including:

- Route of administration (for example, all epidural protocols), or
- Patient type (for example, all pediatric protocols), or
- Any other hierarchy which fits the needs of your institution.

Refer to your facility's policies and procedures to understand how colors are used to identify your pain management protocols.

Pump Status Colors

The colors green, amber, red, and blue are used to help clinicians and patients recognize pump status. Similar to a traffic control light, green means go, amber indicates caution, and red means stop:

- **Green:** Pump conditions are satisfactory. Green numbers in the work area indicate that a programmed value falls *within* the soft limit range for the parameter.
- **Amber:** There is a condition to watch, but the current pump conditions are satisfactory. Medium priority alarms and values *outside* soft limits display in amber.
- **Red:** There is a warning condition that requires immediate attention and infusion has stopped. All high priority and system fault alarms display in red.
- **Blue:** Low priority alarms and informational messages display in blue.

For more information on alarm screens, refer to *Alarms and Messages* on page 113.

Pump Back Label Colors

- **Blue:** CADD[®]-Solis VIP Pump - PharmGuard[®] Software Enabled
- **Green:** CADD[®]-Solis VIP Pump - Select Protocols
- **Black:** CADD[®]-Solis VIP Pump - Standard Settings

Security Settings

Security settings are used to limit patient and unauthorized clinician access to certain programming and operating functions of the pump. Pump functions are protected by 3 different security codes. The security level tables list the functions that are available under each security code. The factory default settings for the security codes are as follows:

- **Keypad Code:** 201
- **Clinician Code:** 997
- **Administrator Code:** 921

WARNING:

- **Do not disclose pump security codes or any other information that would allow the patient or unauthorized clinician complete access to programming and operating functions. Improper programming could result in serious patient injury or death.**
 - **Do not leave the pump unattended while unlocked. All programming functions are accessible while the pump is unlocked, and improper programming could result in serious patient injury or death.**
-

Security Level Tables

- The keypad code is for clinicians who need to modify and review patient-specific parameters, and manage air and occlusion parameter settings.
- The clinician code allows access to all the functions the keypad code allows. In addition, it allows users to modify most advanced tasks parameters, format the time and date, change delayed start and priming security options, and select new protocols.
- The administrator code allows access to all pump functions and allows users to change protocol ranges for patient-specific parameters, reset the pump to factory defaults, and select manual mode protocols. Its use should be restricted to the CADD[®]-Solis system administrator and key individuals.

Security Levels, Pump Operations and Tasks								
Pump Operations and Tasks	Available without a security code		Available with keypad code		Available with clinician code		Available with administrator code	
	Running	Stopped	Running	Stopped	Running	Stopped	Running	Stopped
Stop/Start 	✓	✓	✓	✓	✓	✓	✓	✓
PCA Dose  (PCA only)	*		*		*		*	
Reset Reservoir Volume		✓		✓		✓		✓
Taper Down Now (Taper only)	✓		✓		✓		✓	
Taper Down Period of Taper Down Now (Taper only)			✓		✓		✓	
Set Delayed Start (Not available in Intermittent)		*		✓		✓		✓
Set Next Dose Start Time (Intermittent only)		*		✓		✓		✓
Prime Tubing		*		✓		✓		✓
View Delivery Settings	✓	✓	✓	✓	✓	✓	✓	✓
Edit Delivery Settings (Therapy type determines which submenus appear)				✓		✓		✓
Display and Sound Settings menu	✓	✓	✓	✓	✓	✓	✓	✓
Backlight Intensity	✓	✓	✓	✓	✓	✓	✓	✓
Alarm Volume	✓	✓	✓	✓	✓	✓	✓	✓
Sound Theme	✓	✓	✓	✓	✓	✓	✓	✓
Key Beep On/Off	✓	✓	✓	✓	✓	✓	✓	✓
Numeric Format						✓		✓
Change Time and Date menu		✓		✓		✓		✓
Current Time		✓		✓		✓		✓
Current Date		✓		✓		✓		✓
Time Format						✓		✓
Date Format						✓		✓
View Reports	✓	✓	✓	✓	✓	✓	✓	✓
View Advanced Tasks (see <i>Security Levels, Advanced Tasks</i> on page 22)	✓	✓	✓	✓	✓	✓	✓	✓

Table Key:



Yes



No



* Availability based on facility protocol

Security Levels, Advanced Tasks								
Advanced Tasks	Available without a security code		Available with keypad code		Available with clinician code		Available with administrator code	
	Running	Stopped	Running	Stopped	Running	Stopped	Running	Stopped
Step Down (Step only)	✓	✓	✓	✓	✓	✓	✓	✓
Step Up (Step only)			✓	✓	✓	✓	✓	✓
Give Clinician Bolus (PCA only)					✓		✓	
Patient Permissions						✓		✓
Air and Occlusion Settings				✓		✓		✓
Alarm Settings						✓		✓
Security Settings menu						✓		✓
Keypad Security						✓		✓
Keypad Code						✓		✓
Clinician Code						✓		✓
Admin Code								✓
Manual Programming Security								✓
Start New Patient						✓		✓
Select a manual mode protocol						✓*		✓
Start New Protocol Same Patient						✓		✓
Select a manual mode protocol						✓*		✓
Delivery Hard and Soft Limits menu (Therapy type determines which submenus appear)								✓
Reset to Factory Settings								✓

Table Key:



Yes



No

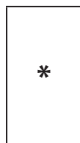

* If a custom drug library is loaded through PharmGuard® Software, selecting manual mode may require the admin code depending on facility protocol.

Autolock

The CADD®-Solis VIP ambulatory infusion pump is designed to meet both safety and usability needs. The autolock feature reduces the chance of unauthorized pump programming. When the keypad is unlocked with a security code and left unlocked, the software automatically locks the keypad.

If the pump is on the home screen, the autolock feature takes effect 30 seconds after the last key press. Autolock takes longer on programming or task screens when the user typically needs more time to perform an action. Depending on which screen was on the pump last, and if the pump is not alarming, it can take up to 4 minutes after the last key press before the pump reverts to the home screen and autolocks immediately. When the pump is alarming, autolock does not take effect.

Note: The keypad can be re-locked by pushing the right soft key twice from the home screen or once from the Tasks or Advanced Tasks menu. As a recommended safety precaution, always manually lock the pump using this feature.





Entering Security Codes

WARNING:

- Do not disclose pump security codes or any other information that would allow the patient or unauthorized clinician complete access to programming and operating functions. Improper programming could result in serious patient injury or death.
- Do not leave the pump unattended while unlocked. All programming functions are accessible while the pump is unlocked, and improper programming could result in serious patient injury or death.

Note: Many of the instructions in this manual include steps to unlock the keypad. This step is required only if the keypad is locked.

To enter a security code when prompted:

1. Press  or  to scroll up or down to the correct digit. Press  or **Accept Value** to advance to the next digit. Once the complete code has been entered, press  or **Accept Value**.
2. If an incorrect code is entered, a wrong code error appears. It includes the security level required to access the function. Select **Retry** to enter the code again.

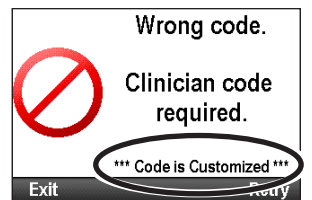
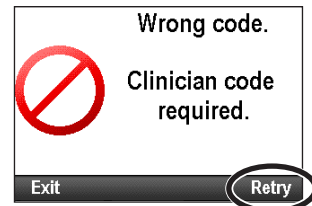
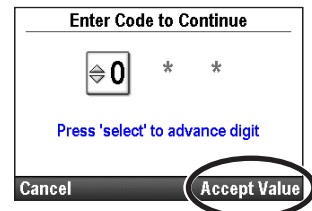

Note: If you enter a code that you believe is correct and receive a wrong code message, check the screen to see if the code has been customized. If the code is not customized, it was entered incorrectly and you should retry. If the code is customized, enter the customized code. If you do not know the code, contact your CADD®-Solis system administrator.

- Depending on the level of security required and how the CADD[®]-Solis system administrator has programmed the security settings, you may be able to use the pump key to unlock the keypad. When accessing a menu or function that requires a security code, 1 of 2 prompts appears, as shown in the sample screens to the right.

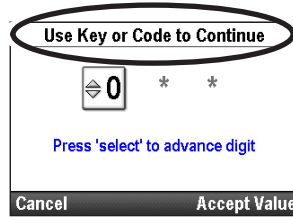

Either the key or a code unlocks the keypad.

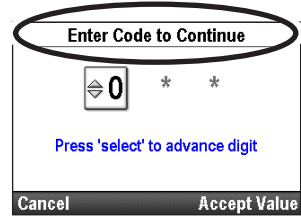

Only a code unlocks the keypad.

To unlock the keypad with the pump key, turn the key counterclockwise.

Note: It is possible for the keypad to be locked while the cassette/keypad lock is unlocked. To use the key to unlock the keypad, first lock the cassette/keypad lock, and then unlock it.

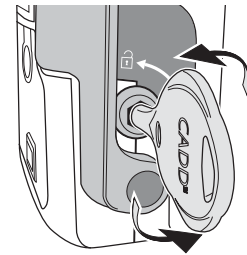

Customized Security Settings

The keypad code, clinician code, and administrator code may be customized by the CADD[®]-Solis system administrator when setting up protocols with the PharmGuard[®] Administrator Medication Safety Software, or in the security settings under Advanced Tasks. See your CADD[®]-Solis system administrator for more information, or to learn the security code you should use if the codes have been customized.

The security settings option in the Advanced Tasks menu allows you to customize the pump security codes. The keypad code, clinician code, and administrator code can all be customized to a unique three-digit number from 001 to 899. If desired, all the codes may be identical. In that case however, all users would have the highest permission level assigned to that code. For example, if the keypad code and clinician codes are the same, each time the code is entered, the user has clinician code permissions. See the security level tables beginning on page 21 for the code permissions.

To access Security Settings:

- From the home screen, select **Tasks**.
- Press or to highlight **View Advanced Tasks** and press .
- Press or to highlight **Security Settings** and press .

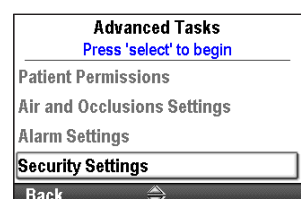
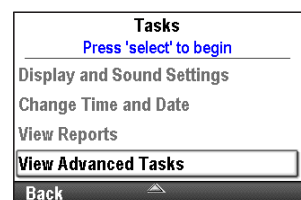
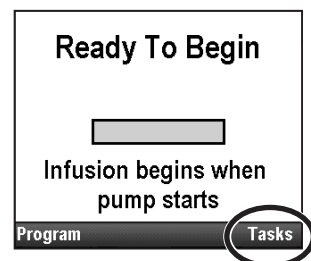

Keypad Security

Under the Keypad Security setting, you may allow the use of the cassette/keypad lock to unlock the keypad. This is done by selecting the Code or Key setting. The use of the key to unlock the keypad allows the same permissions as the keypad code. If the Code Only option is selected, the key will not unlock the keypad.

Note: If the Code Or Key setting is selected, using the key to unlock the keypad is equivalent to entering the keypad code. Use of the key allows clinician or administrator code level access *only if* the keypad code is customized to be the same number as the clinician or administrator code.

To set the keypad security:

1. From the Security Settings menu, press ▲ or ▼ to highlight **Keypad Security** and press **select**.

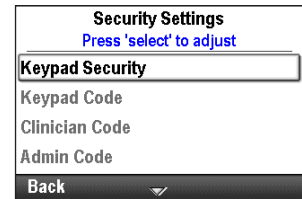

2. Unlock the keypad.
3. Press ▲ or ▼ to highlight **Code Only** or **Code Or Key** and select **Save**.

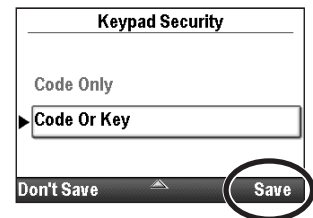

Keypad Code

The default keypad code is **201**. This screen allows you to create a keypad code that is unique to your facility.

Note: The keypad code changes only for the current protocol. The change remains in effect until another protocol is chosen or the same protocol is chosen by using either the Start New Patient task or the Start New Protocol, Same Patient task.

To set the keypad code:

1. From the Security Settings menu, press ▲ or ▼ to highlight **Keypad Code** and press **select**.

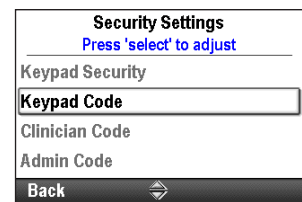

2. Unlock the keypad.
3. Choose any 3-digit combination of numbers from 001 to 899. Press ▲ or ▼ to enter the new code. Press **select** to advance to the next digit. Once the code has been entered, select **Accept Value**.

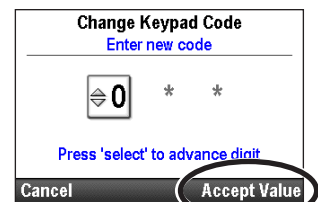

4. Verify the new keypad code by reentering it on the next screen. Once the code has been entered, press **Accept Value**.

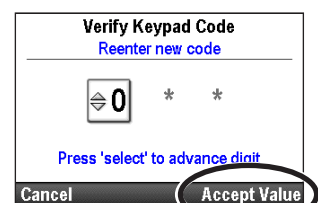

Clinician Code

The default clinician code is **997**. This screen allows you to create a clinician code that is unique to your facility.

Note: The clinician code changes only for the current protocol. The change remains in effect until another protocol is chosen or the same protocol is chosen by using either the Start New Patient task or the Start New Protocol, Same Patient task.

To set the clinician code:

1. From the Security Settings menu, press **▲** or **▼** to highlight **Clinician Code** and press **select**.

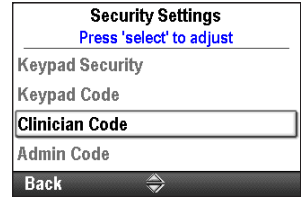

2. Unlock the keypad.
3. Choose any 3-digit combination of numbers from 001 to 899. Press **▲** or **▼** to enter the new code. Press **select** to advance to the next digit. Once the code has been entered, select **Accept Value**.

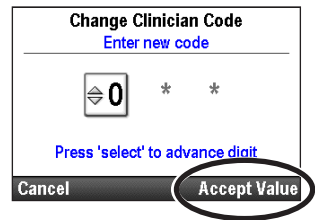

4. Verify the new clinician code by reentering it on the next screen. Once the code has been entered, press **Accept Value**.

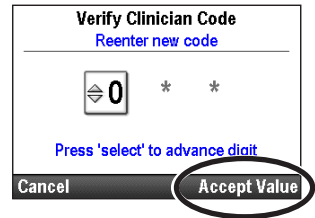

Administrator Code

The default administrator code is **921**. This screen allows you to create an administrator code that is unique to your facility.

Note: The administrator code changes only for the current protocol. The change remains in effect until another protocol is chosen or the same protocol is chosen by using either the Start New Patient task or the Start New Protocol, Same Patient task.

To set the administrator code:

1. From the Security Settings menu, press **▲** or **▼** to highlight **Admin Code** and press **select**.

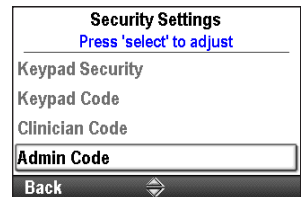

2. Unlock the keypad.
3. Choose any 3-digit combination of numbers from 001 to 899. Press **▲** or **▼** to enter the new code. Press **select** to advance to the next digit. Once the code has been entered, select **Accept Value**.

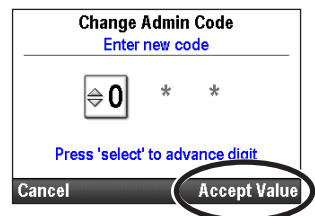



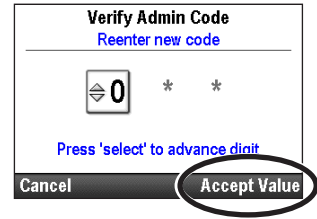

- Verify the new administrator code by reentering it on the next screen. Once the code has been entered, press **Accept Value**.



Manual Programming

The manual programming security option allows you to choose either the clinician or administrator security code to allow access to the manual program protocol.

To select the code for manual programming:

- From the Security Settings menu, press  or  to highlight **Manual Programming Security** and press .
- Unlock the keypad.
- Press  or  to highlight the desired code and select **Save**.

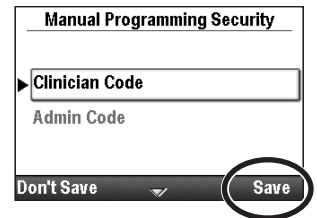
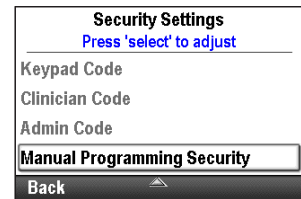

Pump Programming

Quick Access to Manual Programming

If the desired delivery mode (Therapy) is correct, pressing the Program Key provides quick access to the programming parameters. If the current delivery mode is not correct, refer to the New Protocol Selection from Library or Manual Mode, in order to select a different delivery mode (Therapy).

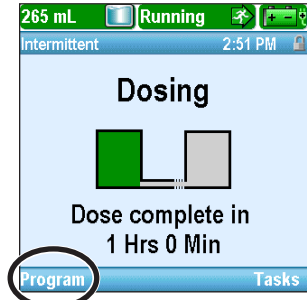

Protocols and Protocol Libraries

A **protocol** is a collection of medication delivery and other pump settings, including administrator settings for the CADD[®]-Solis VIP ambulatory infusion pump, a therapy, qualifier, and drug combination, and other delivery parameters. A collection of protocols in PharmGuard[®] Administrator Medication Safety Software form a **protocol library**. The CADD[®]-Solis system administrator creates, maintains, and loads the libraries onto the PharmGuard[®] Software Enabled CADD[®]-Solis VIP ambulatory infusion pump.

Each protocol includes a therapy, qualifier, and drug.

- **Therapies** are pre-defined and correspond to the delivery modes available on the pump: PCA, continuous, intermittent, step, and taper. No additional therapies can be created.
- **Qualifiers** are specific to a selected therapy and further identify the type of infusion to be delivered. Examples of qualifiers include pediatric, TPN, and epidural.
- **Drugs** are designated by a name/concentration/units/drug ID combination.

The out of the box factory library in PharmGuard and Select pumps use the Qualifiers and Drugs to sort protocols by rate and volume ranges, which is different than how it is described in this manual.

New Protocol Selection

Single Protocol Download (for PharmGuard[®] Software Enabled pumps)

1. Make sure the pump is stopped and on the home screen.
2. Connect the pump to the PC using the USB cable. Use the PharmGuard[®] Administrator Medication Safety Software to load a single protocol on the pump.
3. Acknowledge the low priority alarm.
4. The “Review pump settings” screen appears. Select **Review**.

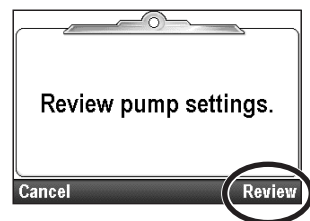

5. Press **▲** or **▼** to scroll through and review all the settings. If the highlighted setting is correct, press **Accept Value**. A green check mark appears next to the setting.

If the highlighted setting is incorrect, press **select** to adjust the setting. Press **▲** or **▼** to modify the setting and then press **Save**.

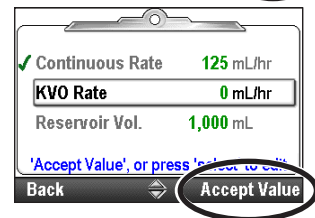

6. When your review is complete, select **Next**.

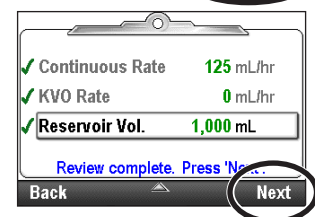

- If a cassette is attached, latched, and locked (if required), the “Start pump?” screen appears. Press **Yes** to start the pump immediately or **No** to start the pump at a later time.

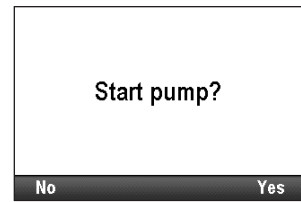

New Protocol Selection from a Library or Manual Mode

Start New Patient

Each time a new patient is started, it is recorded in the event log. All other reports are cleared. Protocol libraries for PharmGuard® Software Enabled pumps are created with the PharmGuard® Administrator Medication Safety Software and are loaded onto the pump by the CADD®-Solis system administrator. Select Protocol pumps have a pre-loaded out of the box factory protocol library. Depending on which pump configuration you are using, you may choose a protocol from a library created by the PharmGuard® Software Administrator, choose a protocol from the pre-loaded out of the box factory protocol library, or manually program the pump.

Start New Protocol Same Patient

The process for starting a new protocol for the same patient is the same as starting a new patient. However, the event log does not insert a new patient marker. All other reports are cleared except the delivery log.

Note: When starting a new protocol, attach a *new* reservoir with the proper medication.

To start a new patient and run an existing protocol from a library:

- Make sure the pump is stopped.
- In the Advanced Tasks menu (see page 102), press **▲** or **▼** to highlight **Start New Patient** or **Start New Protocol Same Patient** and press **select**.

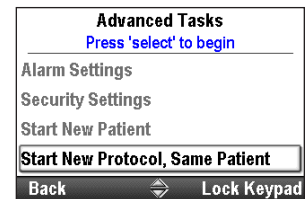
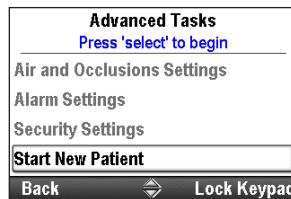

- The next screen informs you that completing this task will overwrite all delivery settings. Press **Continue** to unlock the keypad and continue programming the pump.

Note: To edit individual settings rather than starting a new patient or new protocol, press **Back** two times to reach the Tasks menu. Press **▲** or **▼** to highlight **View Delivery Settings** and press **select**. See page 37 for more information on editing delivery settings.

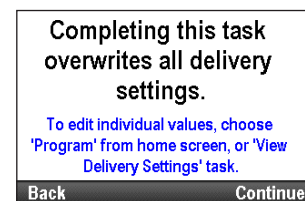

- Unlock the keypad.
- Press **▲** or **▼** to highlight a therapy and press **select**.

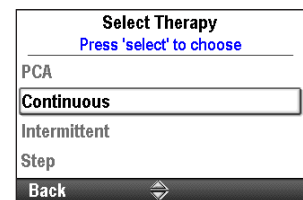

- Press **▲** or **▼** to highlight a qualifier and press **select** (Not applicable to Standard Pumps)

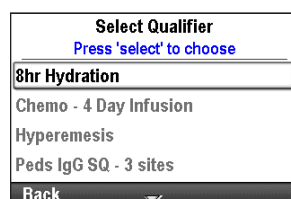

PharmGuard® Example

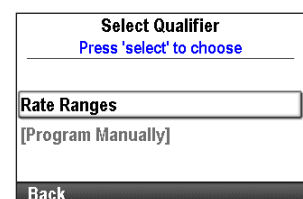

Select Example

7. Press  or  to highlight a drug and press  (Not applicable to Standard Pumps)

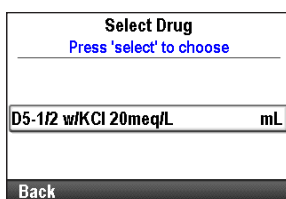

PharmGuard® Example

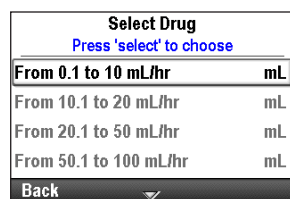

Select Example

8. A screen appears with a summary of your selections. Review them to confirm that you have entered the correct therapy, qualifier, and drug. Select **Yes**. (Not applicable to Standard Pumps)

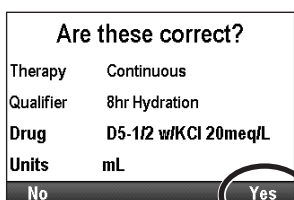

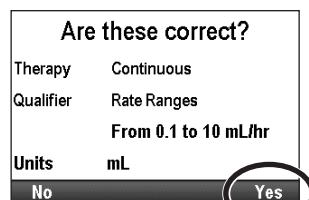

PharmGuard® Example



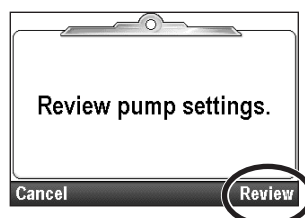

Select Example

9. The “Review pump settings” screen appears. Select **Review**.



10. Press  or  to scroll through and review all the settings. If the highlighted setting is correct, press **Accept Value**. A green check mark appears next to the setting.

If the highlighted setting is incorrect, press  to adjust the setting. Press  or  to modify the setting and then press **Save**.

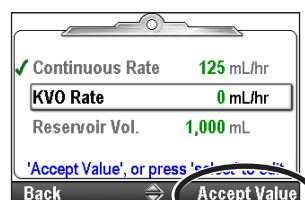

11. When the review is complete, select **Next**.

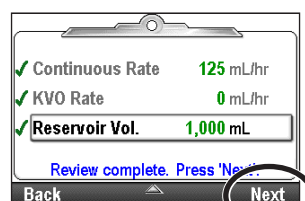

12. When a cassette is attached, latched, and locked (if required by PCA therapies), the "Prime tubing?" screen *may* appear. For more information on priming, see *Prime Tubing* on page 86.

The “Start pump?” screen appears. Select **Yes** to start the pump immediately or **No** to start the pump at a later time.

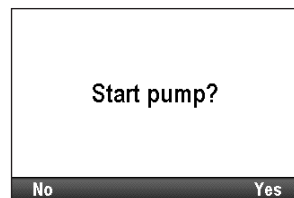

Manually Programmed Protocols

Note: Manual programming is the only option in the Standard pump, and is always an option in the PharmGuard® and Select pumps whenever circumstances arise where the protocols of the library are not suitable for the order received.

Manually programming a protocol or making changes to an individual protocol for a single use may occur when the doctor’s orders do not match any of the protocols in the library, or when a protocol library is not available.

Unlike protocols that are created and downloaded into the pump by the PharmGuard® Administrator Medication Safety Software, manual programming allows you to edit units and concentration (in PCA mode), and does not contain any programming limits. Many of the mode-independent parameters may remain the same as the parameters from the previously used protocol. For example, if the previously used protocol had the pump stopped alarm type set as informational, the manual program also has the pump stopped alarm type set as informational. However, the actual programming limits of the previous protocol are cleared. The hard and soft limits are all set to the factory default, which means the delivery ranges are not limited. See the following chart for details.

Note: If the pump was set to the factory default, or if you are using the pump for the first time, the previously used protocol is the factory default settings. Refer to the tables beginning on page 146.

The following table lists the initial pump settings when programming manually. *Attributes not listed in the table remain the same as the previously used protocol.*

PCA Mode, Specific Attributes	Value Defaults to:
Clinician bolus amount	0 mL
Programming units	mL
Concentration	N/A
Continuous rate	0 mL/hr (or mg or mcg equivalent)
Delivery limit method	Not in use
KVO rate	0 mL/hr (or mg or mcg equivalent)
Maximum delivery rate	125 mL/hr
PCA dose	0 mL (or mg or mcg equivalent)
PCA dose lockout	1 hr
Continuous Mode, Specific Attributes	Value Defaults to:
Continuous rate	0.1 mL/hr
KVO rate	0 mL/hr
Intermittent Mode, Specific Attributes	Value Defaults to:
Dose cycle	24 hr
Dose duration	2 hr
Dose volume	0.1 mL/hr
KVO rate	0 mL/hr
Step Mode, Specific Attributes	Value Defaults to:
Infusion alerts	Off
Initial rate	0.4 mL/hr
KVO rate	0 mL/hr
Plateau rate	0.4 mL/hr
Step duration	30 min
Step rate increment	0.4 mL/hr
Total infusion volume	1 mL
Taper Mode, Specific Attributes	Value Defaults to:
Infusion duration	24 hr
Infusion volume	24 mL
KVO rate	1 mL/hr
Plateau rate upper limit	500 mL/hr
Taper down	0 hr
Taper up	0 hr

Mode-Independent Attributes	Value Defaults to:
Air detector on/off	On
Delayed start requires security	On
Priming requires security	On
Protocol identifiers	Qualifier: [Program Manually] Drug: Non-Library Protocol
Reservoir volume	0 mL
Reservoir volume low trip point	5 mL
Reservoir volume reset value	100 mL
Start time	Now
Unlock with key	False

To start a new patient and manually program the protocol:

1. Make sure the pump is stopped.
2. In the Advanced Tasks menu (see page 102), press or to highlight **Start New Patient** and press .
3. Unlock the keypad.
4. Press or to highlight a therapy and press .

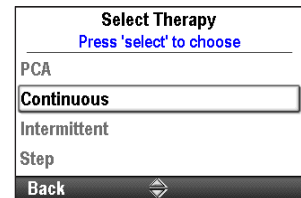

5. Press or to highlight **[Program Manually]** and press . (Not applicable to Standard Pumps.)

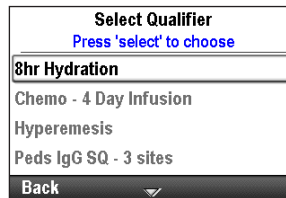

PharmGuard® Example

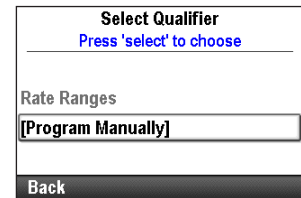

Select Example

6. A screen appears with a summary of your selections. Confirm that the correct information appears, and select **Yes**.

Note: If the information is incorrect, select the left soft key as many times as required to back out of the screen, allowing you to start over. (Steps 5 and 6 are not applicable to Standard Pumps)

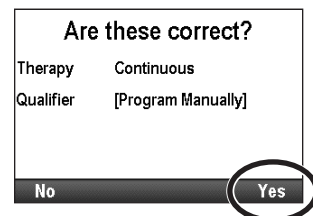

7. The “Review pump settings” screen appears. Select **Review**.

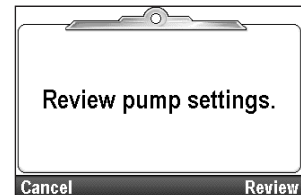

8. Press or to scroll through all the settings. If the highlighted setting is correct, select **Accept Value**. A green check mark appears next to the setting.

If the setting is incorrect, press to edit. Press or to modify the setting and then select **Save** or **Confirm** (see note).

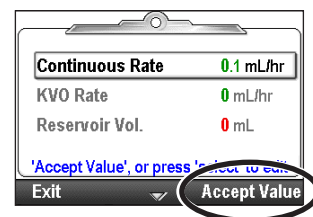

Note: If you edit any of the parameters, you may exceed the soft limit range and must **Confirm** the soft limit override on each screen. The parameter and value will be displayed in amber.

WARNING: The manual program mode does not contain programming limits. Carefully review each parameter to ensure it accurately matches the prescription. Failure to set the manual program to the correct values could result in serious patient injury or death.

9. When the review is complete, select **Next**.



10. Follow the instructions on the pump to attach the cassette, prime, and start the pump.

Delayed Start/Next Dose Start Time

Delayed Start

Note: This task is available for all therapies *except* intermittent. If an intermittent therapy is programmed, this option is not visible under the Tasks menu.

The Set Delayed Start task allows you to delay the start of an infusion by up to 96 hours by selecting the date and time at which the infusion should begin. If Set Delayed Start is programmed, then Start Time is displayed as the last setting on the Delivery Settings screen. This is the time that the next infusion begins. The pump must be running on the selected date and time in order for delivery to begin.

If Set Delayed Start is programmed, the keep vein open (KVO) rate is active until the infusion begins.



Note: *In step and taper therapies, you may not set a delayed start after an infusion has been started.*

To Set Delayed Start:

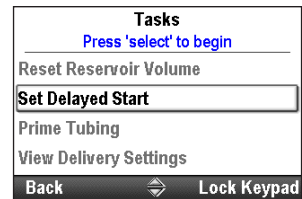
1. From the Tasks menu, press  or  until **Set Delayed Start** is highlighted, and then press .



2. Unlock the keypad, if required.

3. Press  or  until the desired start time appears on the screen, and select **Confirm**.

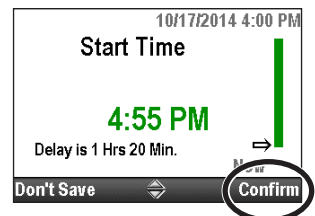

4. Confirm the new start time by selecting **Yes**.

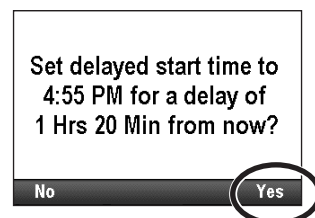

Next Dose Start Time

Note: This task is available for intermittent therapies only. If another therapy type is programmed, this option is not visible under the Tasks menu.

A Next Dose Start Time may be programmed to delay the start of the next dose of an infusion. However if a dose is in progress, this cancels the remainder of the current dose. To avoid interrupting the dose in progress, adjust the next dose start time when the pump is in KVO.

Note: During dosing, the home screen shows “Dosing”. If a dose is stopped in progress, the home screen shows “Interrupted.” If the infusion was in KVO, “Between Doses” appears on the home screen.

The Next Dose Start Time may also be set to delay delivery of the first dose of the infusion by up to 96 hours. The pump must be running on the selected date and time in order for delivery to begin.

To set the next dose start time:



1. Stop the pump if it is running. If a dose was delivering when the pump was stopped, the “Interrupted” screen appears.

Note: If a dose is in progress, this cancels the remainder of the dose.

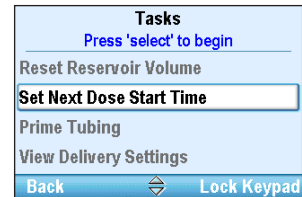
2. From the Tasks menu, press  or  until **Set Next Dose Start Time** is highlighted, and then press .



3. Unlock the keypad, if required.

4. Press  or  until you reach the time that you want the next dose start time to begin. The length of the delay is listed below the time. Select **Confirm**.

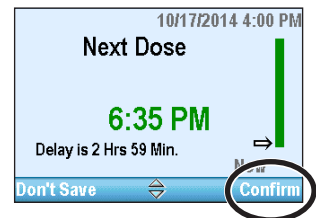

5. A screen appears asking you to confirm the new start time and length of the delay. Select **Yes**.

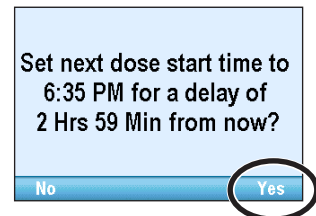

Delivery Hard and Soft Limits











The PharmGuard® Software Enabled pump protocol libraries consisting of therapies, qualifiers, and drugs are created and loaded on the pump using the PharmGuard® Administrator Medication Safety Software. Many of the delivery settings have hard and soft limits assigned to them by the CADD®-Solis system administrator. The Select Pump has therapies, qualifiers and hard limits pre-loaded from the factory. In the unlikely event that any of these values need to be changed manually on the pump, it can be done under the Delivery Hard and Soft Limits setting by a user with the administrator code for all pump configurations.

The delivery hard and soft limits define the ranges that are available when programming delivery settings in the View Delivery Settings menu. Not all of the settings have hard and soft maximum and minimum values. However, the settings still affect the limits that appear in the View Delivery Settings menu. For example, in PCA mode, the Delivery Limit Period, Delivery Limit Amount, and Max Doses/Hr may not appear, based on the value of the Delivery Limit Method.

Default delivery hard and soft limits are listed in the table *Manual Mode Initial Settings* on page 145. The settings are defined below:

- **Hard Maximum:** The maximum value for the parameter being edited. It is not possible to program the setting above the hard maximum value.
- **Soft Maximum:** The soft maximum value should be the highest common value for the setting you are programming. The setting may be programmed above this value, although extra confirmation is required.
- **Current Value:** Displays the current value for the setting in the therapy. Changing this setting changes the programmed value in the current therapy.
- **Soft Minimum:** The soft minimum value should be the lowest common value for the setting you are programming. The setting may be programmed below this value, although extra confirmation is required.
- **Hard Minimum:** The minimum value for the parameter being edited. It is not possible to program the setting below the hard minimum value.

To set the delivery hard and soft limits:

1. Make sure the pump is stopped.
2. In the Advanced Tasks menu (see page 102), press  or  to highlight **Delivery Hard and Soft Limits** and press .
3. Press  or  to scroll to and highlight the setting you want to adjust and press . In this example, only 1 setting is adjustable.
4. Unlock the keypad.
5. Press  or  to scroll to and highlight the setting you want to adjust and press .
6. Press  or  to increase or decrease the limit for the setting and select **Save**.
7. Continue to scroll through the settings until you have set limits for all the values that you want to set. Select **Back** to go back to the Delivery

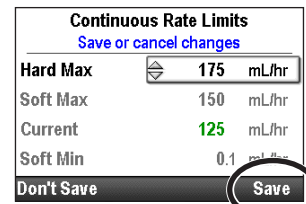
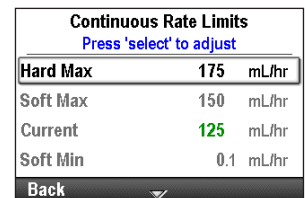
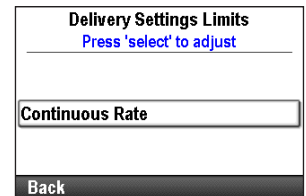
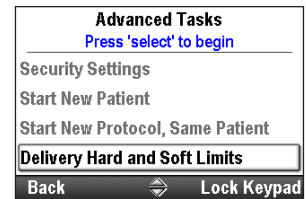

Settings Limits menu. Press **▲** or **▼** to scroll to any other setting you want to adjust, or press **Back** to finish.

Delivery Settings

The delivery settings are patient-specific parameters of a therapy that are directly related to the drug being infused and can be edited within limits established in the protocol. The CADD[®]-Solis system administrator establishes the initial values of the parameters, any applicable programming units and drug concentration, other parameter limits, and which parameters can be viewed and/or edited. A security code (or the pump key, if enabled) are required to edit the parameters.

The delivery settings are programmed by the CADD[®]-Solis system administrator through the PharmGuard[®] Administrator Medication Safety Software. They may also be manually programmed through the Advanced Tasks menu when setting up a new protocol or new patient.

WARNING: The manual program mode does not contain programming limits. Carefully review each parameter to ensure it accurately matches the prescription. Failure to set the correct values could result in serious patient injury or death.

When programming the initial values for a protocol, the CADD[®]-Solis system administrator also sets the hard and soft limits, which may allow you to modify the parameters as necessary. Any programmed value within and including the soft limits is displayed in green, and is the range most commonly used for the protocol. Any programmed value outside the soft limits but within the hard limits is displayed in amber. The hard limits are the highest and lowest values that can be programmed for each protocol. Changes to any of these settings have a direct impact on the amount of drug delivered to the patient, and any changes made in the Delivery Settings menu affect only the therapy that is currently programmed. If the prescribed orders do not match the initial values, the values should be edited to match. Editing the parameters above or below the soft limits results in a screen that requires you to confirm the soft limit override.

Delivery settings specific to each therapy are shown in the table below.

Delivery Settings				
PCA (See page 39)	Continuous (See page 49)	Intermittent (See page 53)	Step (See page 61)	Taper (See page 71)
Continuous Rate	Continuous Rate	Dose Volume	Infusion Volume	Infusion Volume
Units ⁵				
Concentration ^{4,5}				
PCA Dose		Dose Duration	Initial Rate	Taper Up
PCA Lockout ¹		Dose Cycle	Rate Increment	Taper Down
Delivery Limit ²		Dose Rate	Plateau Rate	Infusion Duration
Max Doses/Hr ²		Next Dose	Step Duration	Plateau Rate
		Infusion Duration		
KVO Rate	KVO Rate	KVO Rate	KVO Rate	KVO Rate
Reservoir Vol.	Reservoir Vol.	Reservoir Vol.	Reservoir Vol.	Reservoir Vol.
Start Time ³	Start Time ³		Start Time ³	Start Time ³

¹ This setting does not appear if the PCA dose is zero.

² This setting may not appear, depending on the delivery limit method selected.









³ This setting appears only if a delayed start is in effect.

⁴ This setting is not available if programming units are mL.

⁵ Programming units and concentration are not editable in the parameter list for library protocols (only editable for manual mode).

Editing Delivery Settings

To view and edit delivery settings:

1. Stop the pump if it is running.
2. In the Tasks menu (see page 141), press  or  until **View Delivery Settings** is highlighted, and then press .
3. Press  or  until the desired setting is highlighted, and then press .
4. If requested, unlock the keypad.
5. Press  or  until the desired value appears on the screen, then select **Save**.

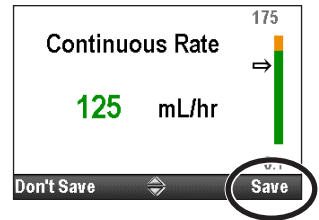
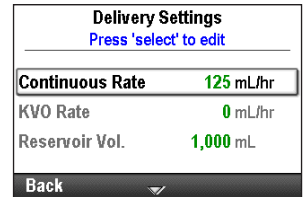
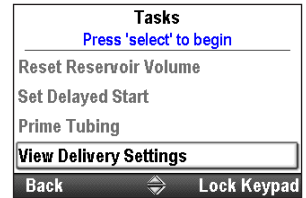

Note for PharmGuard® Software Enabled and Select Pumps

only: If the new value is above the maximum soft limit or below the minimum soft limit, it appears in amber on the screen. To select a value above the maximum soft limit or below the minimum soft limit, select **Confirm** and then select **Yes**.

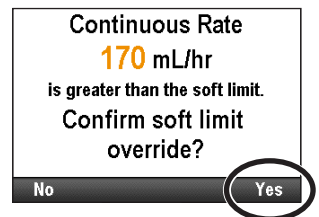
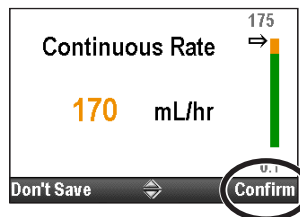

Change any additional settings by scrolling through the remaining delivery settings until all values are correct.

Note: Changes to any of the delivery settings must be confirmed and accepted in a pump settings review. The confirmation requires a security code and must take place before the pump will start. Press stop/start  to display the "Review pump settings" screen (see page 38).

Review Pump Settings

When starting a new patient or a new protocol for the same patient (see page 29), or after adjusting any delivery settings (see page 37), the pump settings must be reviewed and accepted as accurate.

WARNING: Always carefully review the program on the pump after it has been programmed to verify that the pump is programmed correctly. Failure to do so could result in undesired programming of the pump and depending on the drug being administered, death or serious injury to the patient.

To review pump settings:

1. When the “Review pump settings” screen appears, select **Review**.

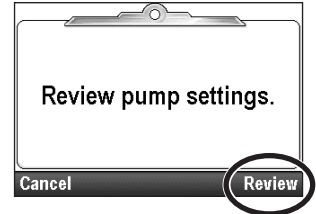

2. Press **▲** or **▼** to scroll through and review all the settings. If the highlighted setting is correct, press **Accept Value**. A green check mark appears next to the setting and the next setting is highlighted.

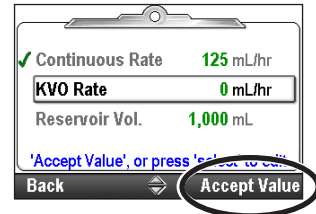

If the highlighted setting is incorrect, press **select** to edit the setting. Press **▲** or **▼** to modify the setting and then press **Save** or **Confirm**.

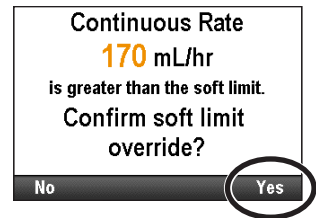
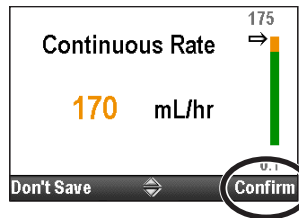

Note for PharmGuard® Software

Enabled and Select Pumps only: If the new value is above the maximum soft limit or below the minimum soft limit, it appears in amber on the screen. To select a value above the maximum soft limit or below the minimum soft limit, select **Confirm**, and then select **Yes** to confirm the soft limit override.

3. When the review is complete, select **Next**.

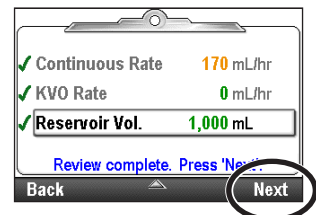

PCA Delivery Mode

PCA (patient-controlled analgesia) delivery is used for therapies that require a continuous rate of infusion, patient-controlled demand doses, and/or a clinician-activated bolus. The delivery methods available are:

- Continuous rate
- PCA dose, a demand dose activated by the patient
- Clinician bolus, a dose activated by the clinician

Each of the methods may be programmed individually or in combination with each other. The graph below illustrates the combined delivery methods. Ranges and programming increments are listed in *Specifications (Nominal)* on page 128.

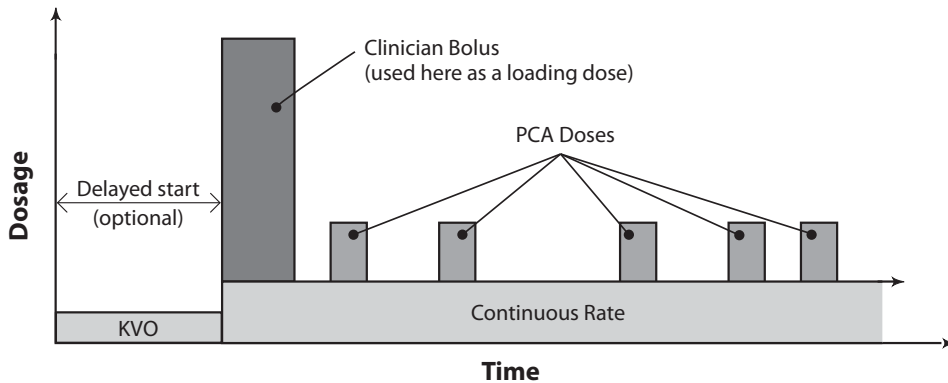

Home Screen

The delivery mode and status of the infusion are indicated on the home screen with messages appearing in text, a graphic in a shape unique to the therapy, and with the colors green, red, and gray. The colors indicate that the pump is running (green), or stopped (red). If a new patient or new infusion is programmed but *the pump has not been started*, or if a delayed start time was programmed and the start time passed while the pump was stopped and not yet started, the graphic is entirely gray. The location of the color on the graphic also indicates the status of the infusion. The examples below are specific to the PCA delivery mode.

- The pump is stopped with a programmed delayed start.
- The pump is running and delivering at a continuous rate.
- The pump is running and delivering a PCA bolus.

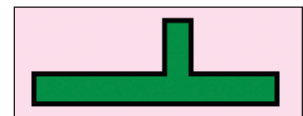
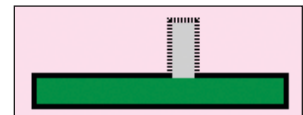
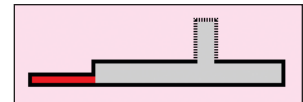

PCA graphics do **not** depict the following:

- The amount of the PCA dose compared to the continuous rate.
- The number of PCA doses attempted or delivered.

Programming Screens

Units

This is the unit of measure, in milligrams, micrograms, or milliliters, for programming of other parameters. For example, the PCA Dose value will be a measure of the units, and the continuous rate value will be a measure of the units per hour. If the units are milligrams or micrograms, a concentration will be required.

Concentration



This is the quantity of drug, by either milligram or microgram, per milliliter of solution. If the units are mL, then the concentration is not applicable and will not display in the parameter list.

Continuous Rate

This is the desired continuous rate of medication delivery. If the prescription does not call for a continuous rate during a PCA therapy, enter 0.

The continuous rate value may be changed by scrolling up or down between the hard maximum and hard minimum settings.

PCA Dose

This is the amount of drug delivered when the patient requests a PCA dose by either pressing the PCA dose  key or using the remote dose cord button. The PCA dose  key on the pump is inactive when the remote dose cord is connected to the pump. If the prescription does not call for a PCA dose, enter 0.

WARNING: The remote dose cord is for patient use only. Operation by anyone other than the patient may cause overdosing of medication that could result in serious injury or death of the patient.

PCA Lockout

This is the minimum time that must elapse between the time one PCA dose starts and the time that the next PCA dose is available.

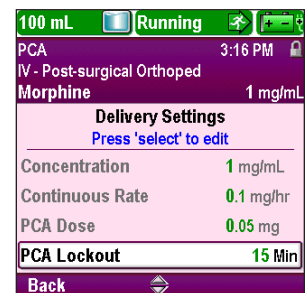
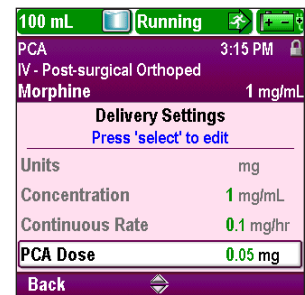
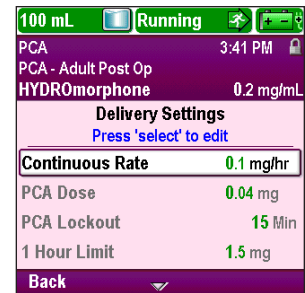
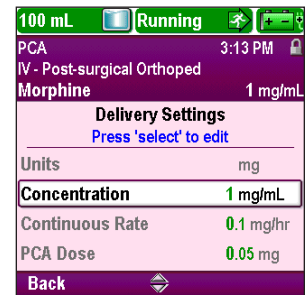
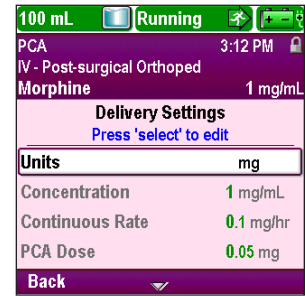

Delivery Limit

This is used to restrict the amount of drug delivered to the patient within a specified time frame. The programmable range is 1 hour to 12 hours. The limit includes the continuous rate and PCA doses, but does not include clinician boluses.

The frequency of available doses are limited by the programmed PCA lockout time. If the delivery limit is reached while a PCA dose is in progress, the PCA dose will not be completed. If the delivery limit is not visible in the menu, your CADD®-Solis system administrator has elected not to require it.

Max Doses/Hr

This is the maximum number of PCA doses allowed in a 1 hour period. The frequency of available doses are limited by the programmed PCA lockout time. If the PCA Lockout is 1 hour or greater, this setting will not appear in the menu. If the setting is not visible in the menu, your CADD®-Solis system administrator has elected not to require it.

KVO Rate

The KVO or “keep vein open” rate allows the delivery of a minimal amount of drug to help maintain catheter patency. If a continuous rate is programmed, the KVO rate automatically displays 0.1 mL/hr (or the mg or mcg equivalent). If no continuous rate is programmed, the KVO rate automatically displays 0 mL/hr (or the mg or mcg equivalent).

The KVO is active under 2 conditions: If a delayed start is programmed, the KVO rate is active until the infusion begins. If a delivery limit is programmed, the KVO rate becomes active when the delivery limit is reached.

Reservoir Vol.

This is the volume of fluid contained in the reservoir. The reservoir volume value decreases as the pump is primed or delivers fluid.

The CADD®-Solis system administrator may choose a standard reservoir volume which allows the reservoir volume to be quickly reset to that value. The clinician can edit the reservoir volume to another amount. This change is for the current protocol only and remains in effect until the Start New Patient or Same Patient New Protocol task is selected.

Start Time

If Set Delayed Start is programmed (see page 33) then Start Time is displayed. This is the time that the next infusion will begin. The pump must be running on the selected date and time in order for delivery to begin.

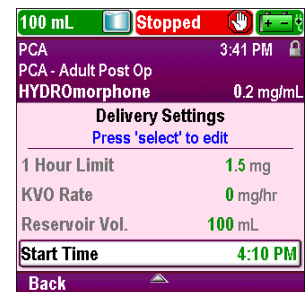
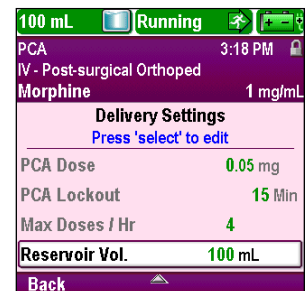
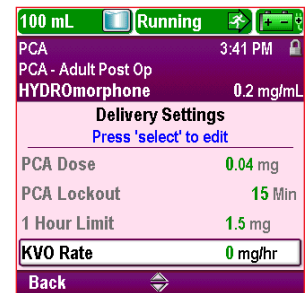
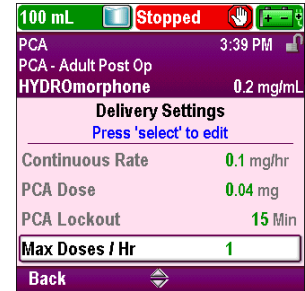
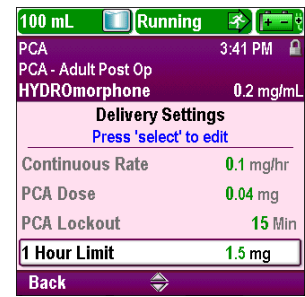

PCA

Programming Example

(using a PharmGuard® Software Enabled Pump with a customized drug library)

WARNING: Ensure that the $\pm 6\%$ system delivery accuracy specification is taken into account when programming the pump and/or filling the reservoir. Failure to do so may result in medication in the reservoir becoming depleted sooner than expected. If the pump is used to deliver critical or life-sustaining medication, the interruption in the delivery of medication could result in patient injury or death.

Example: Medication is provided in a 100 mL CADD™ medication cassette reservoir at a concentration of 10 mg/mL. The patient must receive medication at a continuous rate of 5 mg/hr. PCA doses of 2 mg are allowed with a 15 minute lockout time between doses and a maximum of 2 doses per hour.

1. Select the Therapy

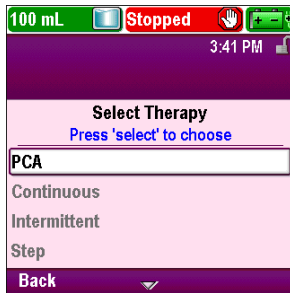

- Stop the pump if it is running.
- Select **Tasks**, then **View Advanced Tasks**, and then **Start New Patient**.
- Unlock the keypad.
- Press **▲** or **▼** to highlight the **PCA** therapy and press **select**. See *Start New Patient* on page 29 if you need more information on selecting the therapy.

2. Select the Qualifier

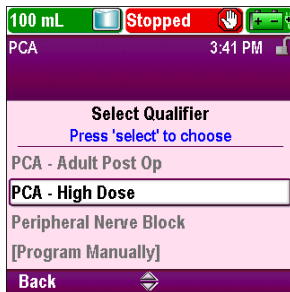

- Press **▲** or **▼** to highlight the desired qualifier and press **select**.

3. Select the Drug

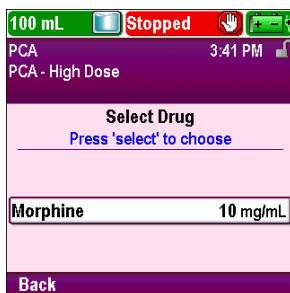

- Press **▲** or **▼** to highlight the desired drug and concentration, and press **select**.

4. Confirm and Review the Settings

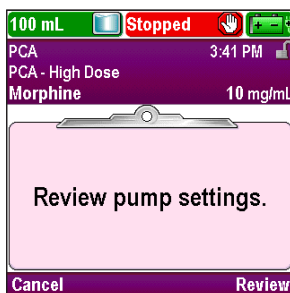
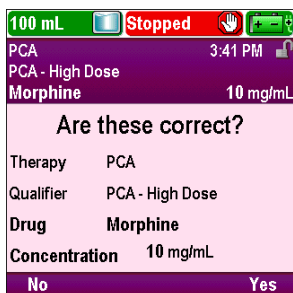

- Review the information on the screen and select **Yes** if they are correct, or **No** to edit the settings.
- The pump displays the **Review pump settings** screen. Select **Review** to continue.

5. Confirm Units

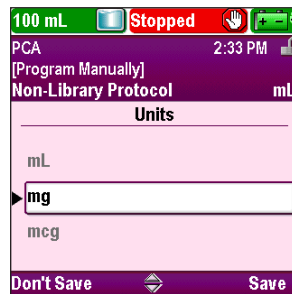
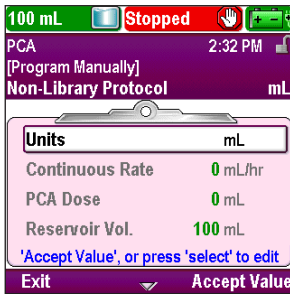

- Press **▲** or **▼** to highlight **Units**. If the value shown is set at the desired unit, select **Accept Value** and go to step 6. If the value shown is not the desired unit, press **select** if in manual mode. If not in manual mode, a different library protocol must be chosen.

6. Confirm Concentration

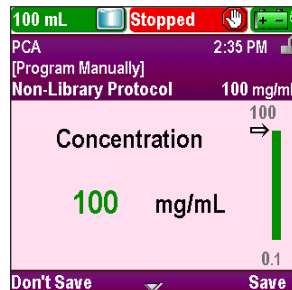

- Press **▲** or **▼** to highlight **Concentration**. If the value shown is set at the desired concentration, select **Accept Value** and go to step 7. If the value shown is not the desired value, press **select** if in manual mode. If not in manual mode, a different library protocol must be chosen.

7. Enter the Continuous Rate

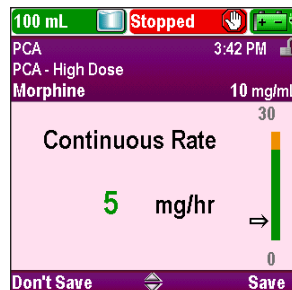
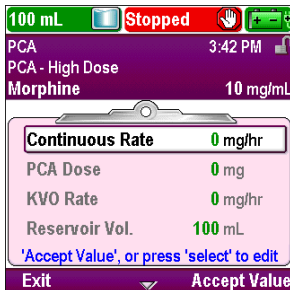

- Press **▲** or **▼** to highlight **Continuous Rate**. If the value shown is set at the desired rate, select **Accept Value** and go to step 6. If the value shown does not show the desired rate, press **select**.
- Press **▲** or **▼** until the value reads **5 mg/hr** and select **Save**.
- The pump returns to the Review screen.

8. Enter the PCA Dose

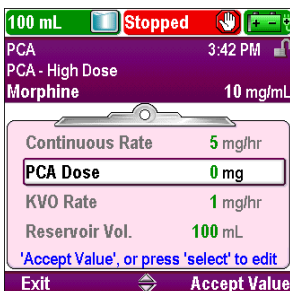

- Press **▲** or **▼** to highlight **PCA Dose**. If the value shown is set at the desired dose, select **Accept Value** and go to step 7. If the value shown does not show the desired dose, press **select**.

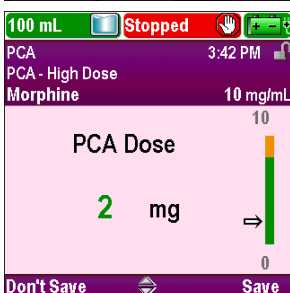

- Press **▲** or **▼** until the value reads **2 mg** and select **Save**.
- The pump then returns to the Review screen.

9. Enter the PCA Lockout

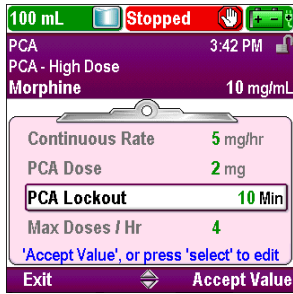

- Press **▲** or **▼** to highlight **PCA Lockout**. If the time shown is set at the desired value, select **Accept Value** and go to step 8. If the value shown does not show the desired time, press **select**.

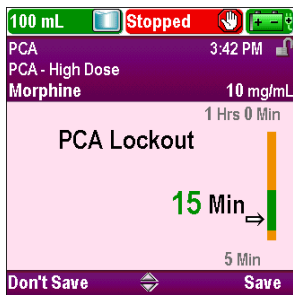

- Press **▲** or **▼** until the value reads **15 Min** and select **Save**.
- The pump then returns to the Review screen.

10. Enter the Maximum Doses per Hour

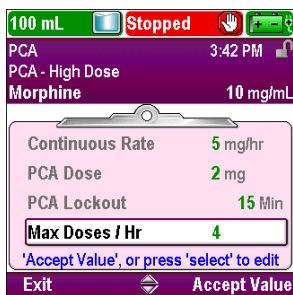

- Press **▲** or **▼** to highlight **Max Doses/Hr**. If the value shown is correct, select **Accept Value** and go to step 9. If the value is not correct, press **select**.

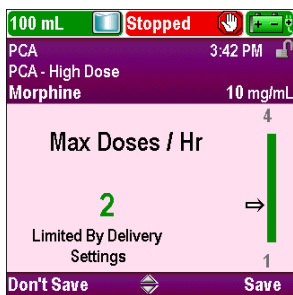

- Press **▲** or **▼** until the value reads **2** and select **Save**.
- The pump then returns to the Review screen.

11. Review the KVO Rate

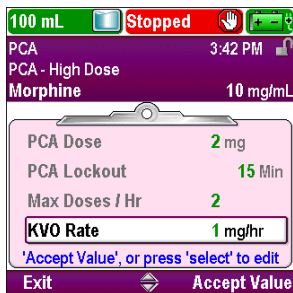

- In this example, the KVO Rate is a calculated value and cannot be edited. This will only display if a delayed start has been programmed.

12. Enter the Reservoir Volume

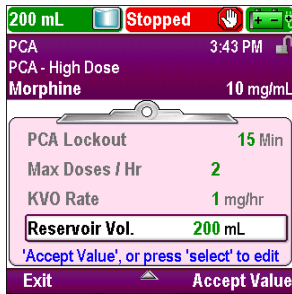

- Press **▲** or **▼** to highlight **Reservoir Vol.** If the value shown is correct, select **Accept Value** and go to step 11. If the value is not correct, press **select**.

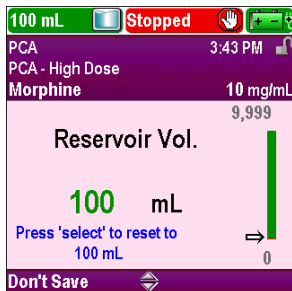

- Press **▲** or **▼** until the value reads **100 mL** and select **Save**.
- You may press **select** to reset the pump to a default amount which appears on the screen in blue text under the current value. In this example, pressing **select** resets the reservoir volume to 100 mL.
- The pump then returns to the Review screen.

13. Accept Values

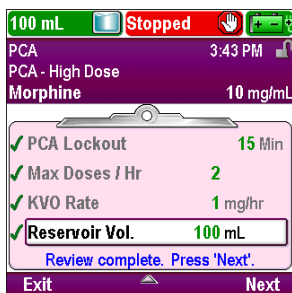

- If any values have not already been accepted, press **▲** or **▼** to highlight each setting and select **Accept Value** if the setting is correct. A green check mark appears next to each accepted value.
- After your review is complete, select **Next**.

14. Prepare the Pump for the Patient

- Follow the instructions for attaching a cassette, priming, and attaching the pump to the patient in *Operating the Pump* on page 80.

Give a Clinician Bolus



WARNING: Exercise care when using the clinician bolus function. Because there are no limits to the frequency of delivering a bolus, and because the bolus amount may be set as high as 50 mL (or the mg or mcg equivalent), you should not permit the patient or unauthorized clinician to become familiar with the procedure for giving a clinician bolus. Improper programming could result in serious patient injury or death.

A clinician bolus may be delivered only when the pump is running. It allows delivery of a specified amount of drug, for example, as a loading dose. A clinician bolus cannot be started while a PCA dose is in progress. The amount delivered decreases the reservoir volume and increases the given amount, but does not add to the dose counters or to the delivery limit. A clinician bolus may be stopped in progress.

Note:

- If a clinician bolus is manually stopped by a clinician, or automatically stopped by an alarm, power failure, or other condition that stops delivery, the pump remembers at what point the bolus was when it stopped. The next time a clinician bolus is given, you will have the option to restart the clinician bolus where it left off, or to start with a new clinician bolus.
- The maximum clinician bolus may be limited by the settings in the protocol, which is determined by the CADD®-Solis system administrator.

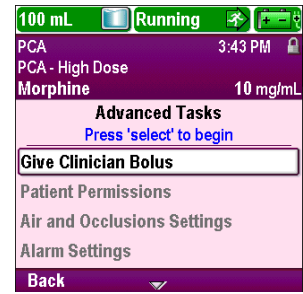

To start a clinician bolus:

1. Make sure the pump is running.
2. From the Advanced Tasks menu (see page 141), press  or  to highlight **Give Clinician Bolus** and press .



3. Unlock the keypad.

WARNING: To prevent the patient from accessing the clinician bolus function, do not let the patient know the clinician or administrator security codes. Improper programming could result in serious patient injury or death.

4. Press  or  to change the value of the clinician bolus. Select **Deliver**.

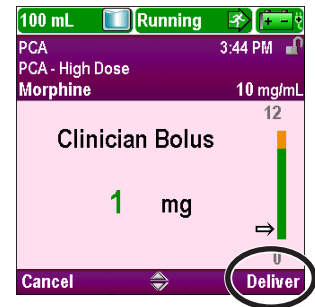

5. If you enter a value outside the soft limit, a screen appears asking you to confirm the soft limit override. Select **Confirm** to deliver the bolus.

WARNING: Never leave the pump unattended while on the clinician bolus edit screen. You must deliver the programmed value, or cancel and leave the screen. Failure to do so could result in serious patient injury or death.

6. The screen shows the decreasing amount as the bolus is delivered. You may stop the bolus at any time by selecting **Stop Bolus**.

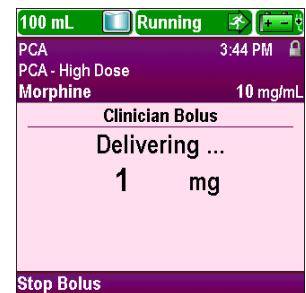

7. When the bolus has been delivered, the screen says, "Clinician bolus complete." Select **OK**.

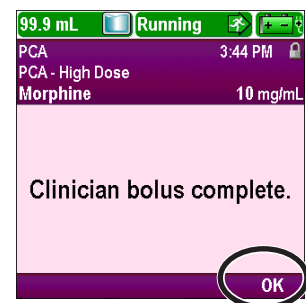

Start a PCA Dose

If a PCA dose is programmed, the patient may start a PCA dose while the pump is running. The amount delivered is added to the amount provided by the continuous rate. Each time the patient requests a PCA dose, the pump automatically adds it to the Given and PCA Dose Counters report. If no PCA dose is programmed, the pump displays the message “PCA dose not available because no dose programmed.”

If the patient attempts to deliver a PCA dose during the lockout time, “PCA dose not available. Currently locked out.” appears on the display and the pump will not deliver the dose. The lockout time is determined by the PCA Lockout or the Max Doses/Hr (if in use), **whichever limits the dose frequency more**. The attempt is added to the Attempted counter on the Given and PCA Dose Counters and the PCA Dose Graph reports.

The remote dose cord can be attached to the pump and provided to the patient as an alternative to pushing the PCA dose  key when requesting a PCA dose. The LED on the remote dose cord indicates PCA dose status:



Off: A PCA dose is not available.

Flashing: A PCA dose is available.

On: A PCA dose has been requested and delivery has started.

WARNING: The remote dose cord is for *patient use only*. Operation by anyone other than the patient may cause overdosing of medication that could result in serious injury or death of the patient.

Note:

- A PCA dose cannot be started while another PCA dose or a clinician bolus is in progress.
- The PCA dose  key on the pump is inactive when the remote dose cord is connected to the pump
- Even if the display has automatically blanked, pressing the PCA dose  key turns the display back on and delivers a PCA dose, if available.

To start a PCA dose:

Press the PCA dose  key on the pump or the remote dose cord. Select **OK**. (If OK is not selected, the screen returns to the previous screen after 5 seconds.)

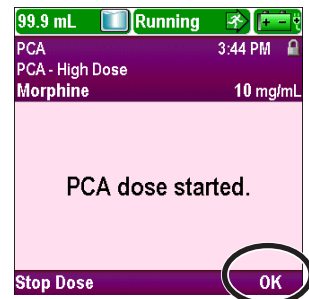

Stopping a Clinician Bolus or PCA Dose

To stop a clinician bolus:

While the clinician bolus is delivering, the Clinician Bolus screen appears on the pump and shows the decreasing amount of the bolus remaining to be delivered. You may stop the clinician bolus from this screen by selecting **Stop Bolus**.

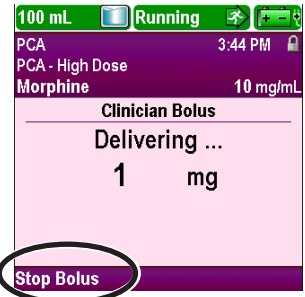

To stop a PCA dose:

1. From the "PCA dose started" screen you may stop the PCA dose while it is delivering by selecting **Stop Dose**.

OR

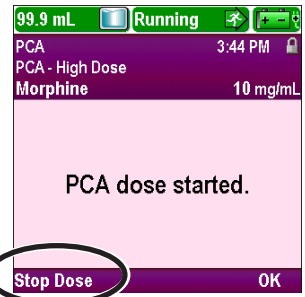

2. If the pump is on the home screen, press the stop/start  button. When the "Stop PCA dose?" screen appears, select **Yes**.

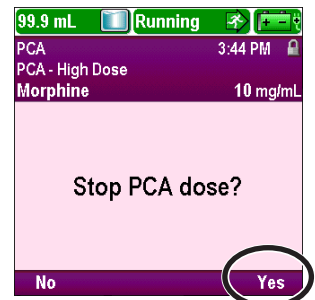

You will be asked if you want to stop the pump as well as the PCA dose. Select **No** to stop only the PCA dose.

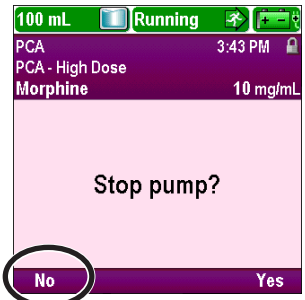

Continuous Delivery Mode

Continuous delivery allows the infusion of drug at a constant, programmed rate. The following graph illustrates an example continuous delivery.

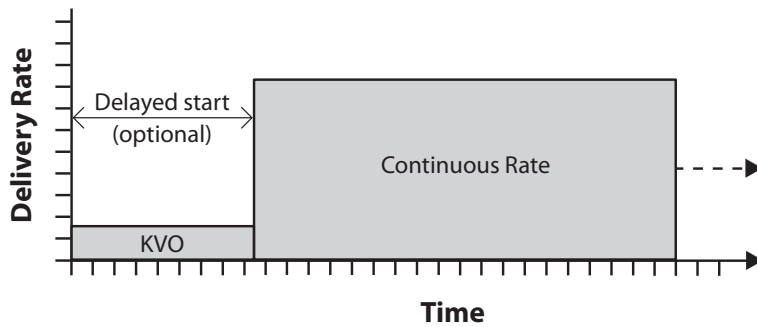

Home Screen

The delivery mode and status of the infusion are indicated on the home screen with messages appearing in text, a graphic in a shape unique to the therapy, and with the colors green, red, and gray. The colors indicate that the pump is running (green), or stopped (red). If a new patient or new infusion is programmed but *the pump has not been started*, or if a delayed start time was programmed and the start time passed while the pump was stopped and not yet started, the graphic is entirely gray. The location of the color on the graphic also indicates the status of the infusion. The examples below are specific to the continuous delivery mode.

- The pump is running at the KVO rate with a programmed delayed start.
- The pump is stopped. It will deliver at a continuous rate once it is started.

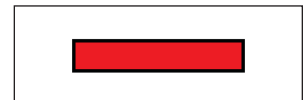
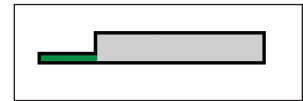

Continuous delivery mode graphics do *not* depict the relative rate of delivery.

Programming Screens

Continuous Rate

This is the desired continuous rate of medication delivery. Rates above 250 mL/hr require a CADD® high volume administration set. The continuous rate value may be changed by scrolling up or down between the hard maximum and hard minimum settings.

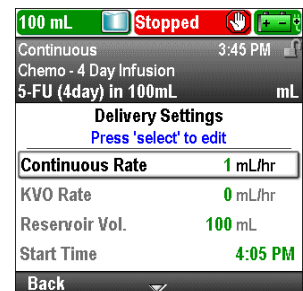

KVO Rate

The KVO or “keep vein open” rate is optional. It allows the delivery of a minimal amount of drug to help maintain catheter patency. The KVO rate is active only if a delayed start is programmed. The pump infuses at the KVO rate until the programmed infusion begins.

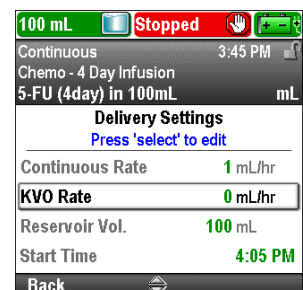

Reservoir Vol.

This is the volume of fluid contained in the reservoir. The reservoir volume value decreases as the pump is primed or delivers fluid.

The CADD®-Solis system administrator may choose a standard reservoir volume which allows the reservoir volume to be quickly reset to that value. The clinician can edit the reservoir volume to another amount. This change is for the current protocol only and remains in effect until the Start New Patient or Same Patient New Protocol task is selected.

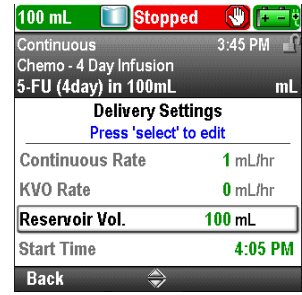

Start Time

If Set Delayed Start is programmed (see page 33) then Start Time is displayed. This is the time that the next infusion will begin. The pump must be running on the selected date and time in order for delivery to begin.

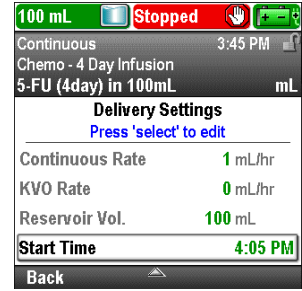

CONTINUOUS

Programming Example

(using a PharmGuard® Software Enabled Pump with a customized drug library)

WARNING: Ensure that the ± 6% system delivery accuracy specification is taken into account when programming the pump and/or filling the reservoir. Failure to do so may result in medication in the reservoir becoming depleted sooner than expected. If the pump is used to deliver critical or life-sustaining medication, the interruption in the delivery of medication could result in patient injury or death.

Example: Medication is provided in a 1000 mL standard IV bag. The patient must receive medication at a continuous rate of 125 mL/hr. The KVO rate should be set to 0 mL/hr.

1. Select the Therapy

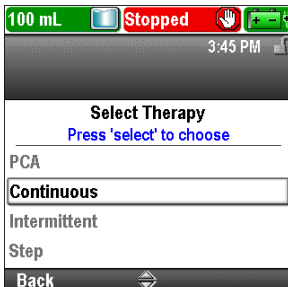

- Stop the pump if it is running.
- Select **Tasks**, then **View Advanced Tasks**, and then **Start New Patient**.
- Unlock the keypad.
- Press **▲** or **▼** to highlight the **Continuous** therapy and press **select**. See *Start New Patient* on page 29 if you need more information on selecting the therapy.

2. Select the Qualifier

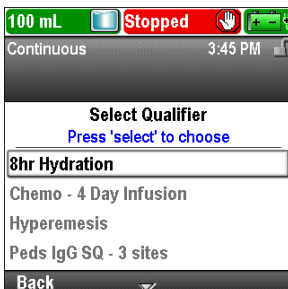

- Press **▲** or **▼** to highlight the desired qualifier and press **select**.

3. Select the Drug

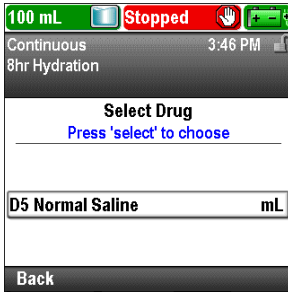

- Press **▲** or **▼** to highlight the desired drug, and press **select**.

4. Confirm and Review the Settings

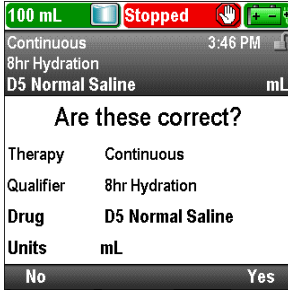

- Review the information on the screen and select **Yes** if they are correct, or **No** to edit the settings.

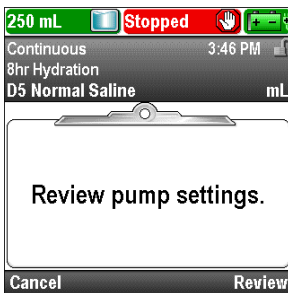

- The pump displays the **Review pump settings** screen. Select **Review** to continue.

5. Enter the Continuous Rate

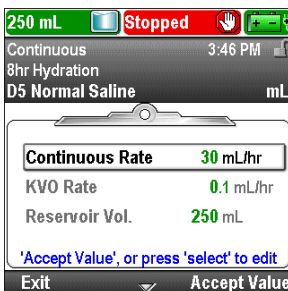

- Press **▲** or **▼** to highlight **Continuous Rate**. If the value shown is set at the desired rate, select **Accept Value** and go to step 6. If the value shown does not show the desired rate, press **select**.

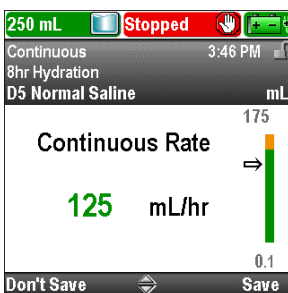

- Press **▲** or **▼** until the value reads **125 mL/hr** and select **Save**.
- The pump returns to the Review screen.

6. Enter the KVO rate

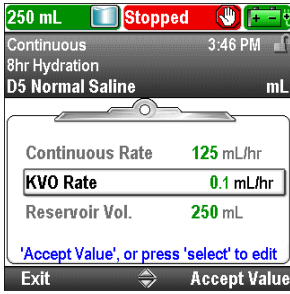

- Press **▲** or **▼** to highlight **KVO Rate**. If the value shown is set at the desired rate, select **Accept Value** and go to step 7. If the value shown does not show the desired rate, press **select**. This will only display if a delayed start has been programmed.

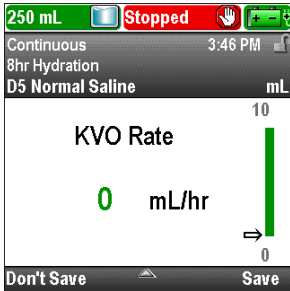

- Press **▲** or **▼** until the value reads **0 mL/hr** and select **Save**. The pump then returns to the Review screen.

7. Enter the Reservoir Volume

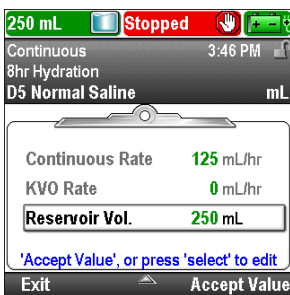

- Press **▲** or **▼** to highlight **Reservoir Vol.**. If the value shown is correct, select **Accept Value** and go to step 8. If the value is not correct, press **select**.

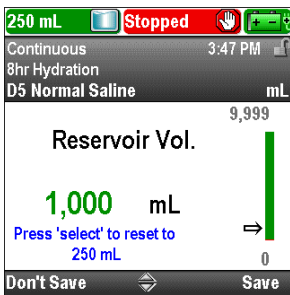

- Press **▲** or **▼** until the value reads **1000 mL** and select **Save**.
- You may press **select** to reset the pump to a default amount which appears on the screen in blue text under the current value. In this example, pressing **select** resets the reservoir volume to 250 mL.
- The pump then returns to the Review screen.

8. Accept Values



- If any values have not already been accepted, press **▲** or **▼** to highlight each setting and select **Accept Value** if the setting is correct. A green check mark appears next to each accepted value.
- After your review is complete, select **Next**.

9. Prepare the Pump for the Patient

- Follow the instructions for attaching a cassette, priming, and attaching the pump to the patient in *Operating the Pump* on page 80.

Intermittent Delivery Mode

Intermittent delivery allows the infusion of a specific volume of drug at a regular, programmed interval and over a specified duration. A dose may be repeated in a cycle up to 96 hours. The KVO (keep vein open) feature allows delivery of a minimal amount of drug between doses to maintain catheter patency. You may also delay the start of the first or next dose by using the Next Dose Start Time task.

The following graph illustrates an example intermittent delivery:

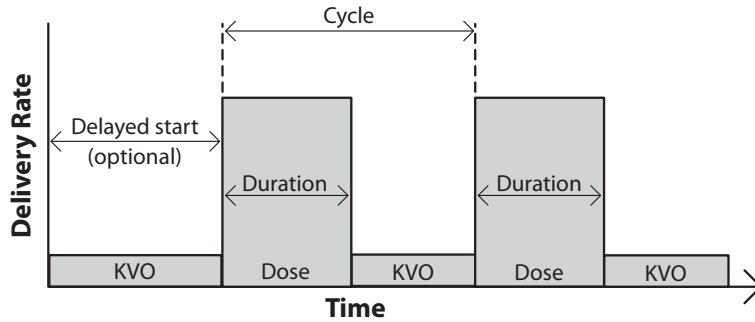

Home Screen

The delivery mode and status of the infusion are indicated on the home screen with messages appearing in text, a graphic in a shape unique to the therapy, and with the colors green, red, and gray. The colors indicate that the pump is running (green), or stopped (red). If a new patient or new infusion is programmed but *the pump has not been started*, or if a next dose start time was programmed and the next dose start time passed while the pump was stopped and not yet started, the graphic is entirely gray. The location of the color on the graphic also indicates the status of the infusion. The examples below are specific to the intermittent delivery mode.

- The pump is running at the KVO rate with a manually programmed next dose start time.
- The pump is running and delivering a dose.
- The pump is stopped between doses while at the KVO rate.

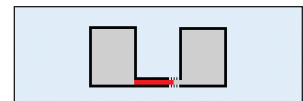
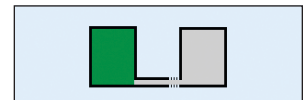
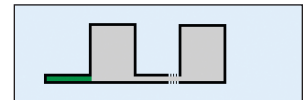

Intermittent delivery mode graphics do **not** depict the following:

- The relative ratio of dose period to dose cycle.
- The number of doses remaining in the current reservoir volume.

Programming Screens

Dose Volume

This is the volume of the dose. The dose volume cannot be programmed to a value that would cause the rate of delivery for the programmed dose duration to exceed the dose rate maximum of 500 mL/hr. Therefore, programming the dose volume may result in the automatic lengthening of the dose duration to accommodate the maximum dose rate. Additionally, there must be at least 5 minutes between the end of one dose and the start of the next dose (the dose cycle must be 5 minutes longer than the dose duration). Therefore, any automatic lengthening of the dose duration may result in an automatic lengthening of the dose cycle in order to maintain the 5 minute difference. Entering a dose volume automatically resets the dose cycle and sets the next dose start time to begin immediately.

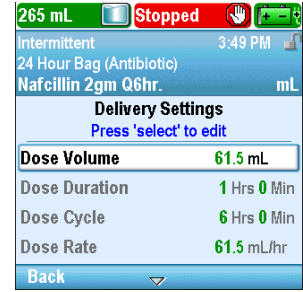

Dose Duration

This is the length of time required to deliver the dose. The dose duration cannot be programmed to a value that would cause the rate of delivery for the programmed dose volume to exceed the maximum dose rate of 500 mL/hr. Additionally, there must be at least 5 minutes between the end of one dose and the start of the next dose (the dose cycle must be 5 minutes longer than the dose duration). Therefore, programming the dose duration may result in an automatic lengthening of the dose cycle in order to maintain the 5 minute difference. Entering a dose duration automatically resets the dose cycle and sets the next dose start time to begin immediately.

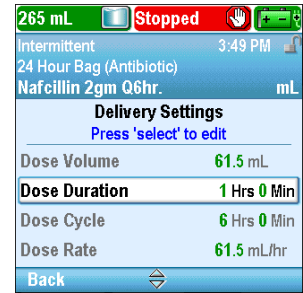

Dose Cycle

This is the time from the start of one dose to the start of the next dose. The programmable values for the dose cycle are dependent on the dose duration. There must be at least 5 minutes between the end of one dose and the start of the next dose (the dose cycle must be 5 minutes longer than the dose duration). Therefore, the minimum programmable cycle is the dose duration plus 5 minutes. The maximum dose cycle is 96 hours. Entering a dose cycle automatically sets the next dose start time to begin immediately.



Dose Rate

This setting is for review only and shows the rate at which the dose is delivered based on the programmed dose volume and dose duration. The maximum allowable rate is 500 mL/hr. Rates above 250 mL/hr require a CADD® high volume administration set.

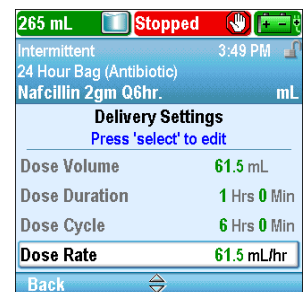

Next Dose

This is the time the next dose is scheduled to begin (see page 34). The pump must be running on the selected date and time in order for the dose to begin. The next dose time can be programmed at any time to delay the start of the next dose, but if a dose is in progress, this cancels the remainder of the dose. While dosing, the home screen shows "Dosing." If a dose is stopped in progress, the home screen shows "Interrupted."



KVO Rate

The KVO or “keep vein open” rate is optional. It allows the delivery of a minimal amount of drug to help maintain catheter patency. If a next dose start time is programmed, the KVO rate is active until the dose begins. It is also active between doses.

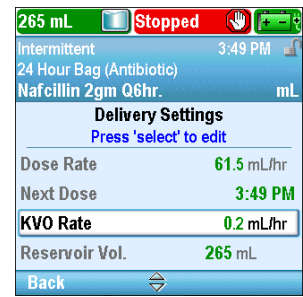

Reservoir Vol.

This is the volume of fluid contained in the reservoir. The reservoir volume value decreases as the pump is primed or delivers fluid. The CADD®-Solis system administrator may choose a standard reservoir volume which allows the reservoir volume to be quickly reset to that value. The clinician can edit the reservoir volume to another amount. This change is for the current protocol only and remains in effect until the Start New Patient or Same Patient New Protocol task is selected.

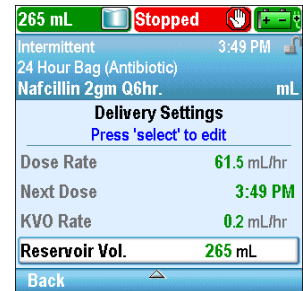

Programming Example

(using a PharmGuard® Software Enabled pump with a customized drug library)

WARNING: Ensure that the $\pm 6\%$ system delivery accuracy specification is taken into account when programming the pump and/or filling the reservoir. Failure to do so may result in medication in the reservoir becoming depleted sooner than expected. If the pump is used to deliver critical or life-sustaining medication, the interruption in the delivery of medication could result in patient injury or death.

Example: Medication is provided in a 100 mL CADD™ medication cassette reservoir. The patient must receive a 23.5 mL dose over 1 hour. The dose must be given every 6 hours with a 0.2 mL/hr KVO rate between doses. The first dose must begin at 8:00 PM tonight.

1. Select the Therapy

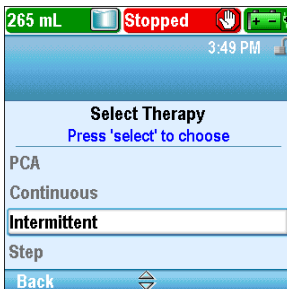

- Stop the pump if it is running.
- Select **Tasks**, then **View Advanced Tasks**, and then **Start New Patient**.
- Unlock the keypad.
- Press **▲** or **▼** to highlight the **Intermittent** therapy and press **select**. See *Start New Patient* on page 29 if you need more information on selecting the therapy.

2. Select the Qualifier

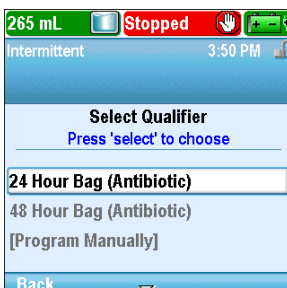

- Press **▲** or **▼** to highlight the desired qualifier and press **select**.

3. Select the Drug



- Press **▲** or **▼** to highlight the desired drug, and press **select**.

4. Confirm and Review the Settings

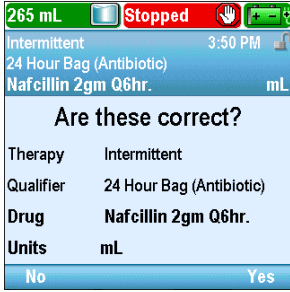

- Review the information on the screen and select **Yes** if they are correct, or **No** to edit the settings.



- The pump displays the **Review pump settings** screen. Select **Review** to continue.

5. Enter the Dose Volume



- Press **▲** or **▼** to highlight **Dose Volume**. If the value shown is set at the desired volume, select **Accept Value** and go to step 6. If the value shown does not show the desired volume, press **select**.



- Press **▲** or **▼** until the value reads **23.5 mL** and select **Save**.
- The pump returns to the Review screen.

6. Enter the Dose Duration



- Press **▲** or **▼** to highlight **Dose Duration**. If the value shown is set at the desired duration, select **Accept Value** and go to step 7. If the value shown does not show the desired duration, press **select**.



- Press **▲** or **▼** until the value reads **1 Hrs 0 Min** and select **Save**. The pump then returns to the Review screen.

7. Enter the Dose Cycle



- Press **▲** or **▼** to highlight **Dose Cycle**. If the value shown is set at the desired cycle, select **Accept Value** and go to step 8. If the value shown does not show the desired cycle, press **select**.

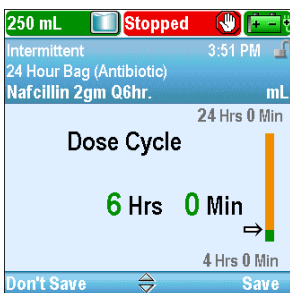

- Press **▲** or **▼** until the value reads **6 Hrs 0 Min** and select **Save**.
- The pump then returns to the Review screen.

8. Enter the Dose Rate



- In this example, Dose Rate is a calculated value and cannot be edited.

9. Enter the Next Dose



- Press **▲** or **▼** to highlight **Next Dose**. If the time shown is correct, select **Accept Value** and go to step 9. If the value is not correct, press **select**.



- Press **▲** or **▼** until the value reads **8:00 PM** and select **Confirm**.

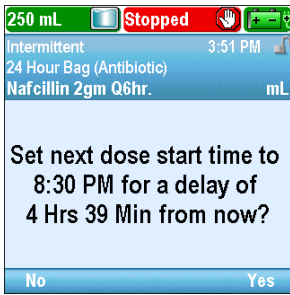

- Confirm the next dose start time by selecting **Yes**.
- The pump then returns to the Review screen.

10. Enter the KVO Rate

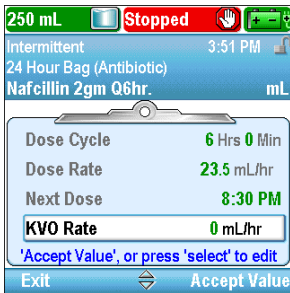

- Press **▲** or **▼** to highlight **KVO Rate**. If the value shown is correct, select **Accept Value** and go to step 10. If the value is not correct, press **select**.



- Press **▲** or **▼** until the value reads **0.2 mL/hr** and select **Save**.
- The pump then returns to the Review screen.

11. Enter the Reservoir Volume



- Press **▲** or **▼** to highlight **Reservoir Vol.** If the value shown is correct, select **Accept Value** and go to step 11. If the value is not correct, press **select**.

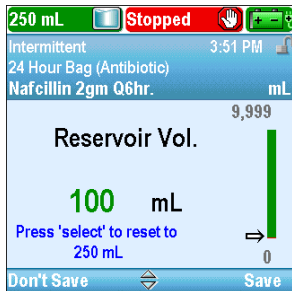

- Press **▲** or **▼** until the value reads **100 mL** and select **Save**.
- You may press **select** to reset the pump to a default amount which appears on the screen in blue text under the current value. In this example, pressing **select** resets the reservoir volume to 250 mL.
- The pump then returns to the Review screen.

12. Accept Values



- If any values have not already been accepted, press **▲** or **▼** to highlight each setting and select **Accept Value** if the setting is correct. A green check mark appears next to each accepted value.
- After your review is complete, select **Next**.

13. Prepare the Pump for the Patient

- Follow the instructions for attaching a cassette, priming, and attaching the pump to the patient in *Operating the Pump* on page 80.

Stopping the Pump During an Infusion

Stopping the pump *between doses* does not affect the start time of subsequent doses.

Stopping the pump *while a dose is in progress* shifts all subsequent doses by the amount of time the pump is stopped (see illustration).

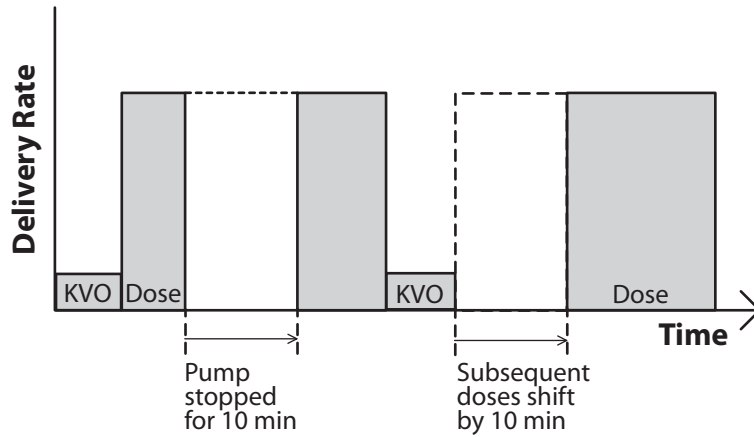

If you want to make up for the time lost in the cycle because the pump was stopped during a dose, **wait until the current dose is completed**. Then, stop the pump and reprogram the Next Dose Start Time. For additional information, see *Next Dose Start Time* on page 34.

Resuming the Dose

To resume delivery of a dose stopped in progress, simply restart the pump by pressing stop/start .

Resetting the Cycle

To reset the cycle, stop the pump between doses, and reprogram the Next Dose Start Time.

When a dose is stopped in progress, the “Interrupted” screen appears. To cancel the current dose and reset the cycle, reprogram the Next Dose Start Time through the Tasks menu. The next cycle will start at the time you select.

See *Next Dose Start Time* on page 34 for more information on setting the Next Dose Start Time.

Step Delivery Mode

Step delivery allows the infusion of a specified volume of drug at an initial rate with linear step increases up to a plateau rate. Multiple steps down may also be applied, reducing the continuous rate as low as the initial rate. An optional KVO (keep vein open) rate may be delivered at the end of the infusion, depending on protocol settings.

The following graph illustrates an example step delivery:

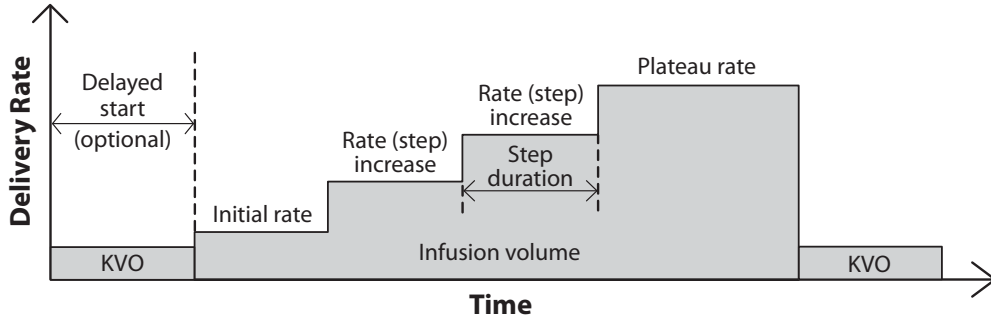

Home Screen

The delivery mode and status of the infusion are indicated on the home screen with messages appearing in text, a graphic in a shape unique to the therapy, and with the colors green, red, and gray. The colors indicate that the pump is running (green), or stopped (red). If a new patient or new infusion is programmed but *the pump has not been started*, or if a delayed start time was programmed and the start time passed while the pump was stopped and not yet started, the graphic is entirely gray. The location of the color on the graphic also indicates the status of the infusion. The examples below are specific to the step delivery mode.

- The pump is running at the KVO rate with a programmed delayed start.
- The pump is stopped and has not yet reached the plateau.
- The pump is running at the plateau rate.
- The pump is running at continuous hold after a manual step down.
- The pump is running at the KVO rate, nearing the end of the infusion.

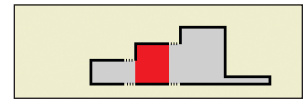
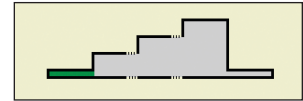

Step delivery mode graphics do **not** depict how many steps will be made to reach the plateau. Nor do they depict the relative step rate increases in comparison to the initial and plateau rates.

Programming Screens

Infusion Volume

This is the total volume of fluid to be delivered. The reservoir volume must be large enough to support the entire infusion volume. Therefore, programming the infusion volume may result in an automatic increase in the reservoir volume.

Entering a new infusion volume resets the infusion so that delivery starts at the beginning.

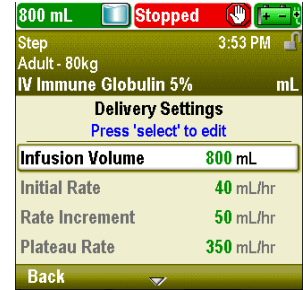

Initial Rate

This is the initial rate of medication delivery. *Entering a new initial rate resets the infusion so that delivery starts at the beginning of the infusion duration.*

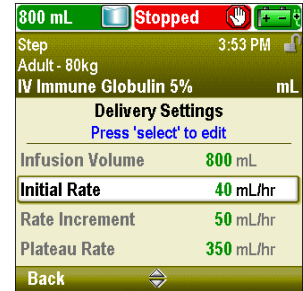

Rate Increment

This is the amount that you want medication delivery to increase by for each step. *Entering a new rate increment resets the infusion so that delivery starts at the beginning.*

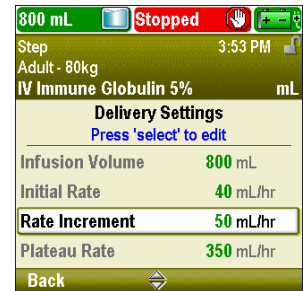

Plateau Rate

This is the maximum rate at which you want the medication to be delivered. The pump begins at the initial rate, and increases by the rate increment until the plateau rate is reached. The pump runs at the plateau rate until the infusion volume is fully delivered.

Entering a new plateau rate resets the infusion so that delivery starts at the beginning.

Rates above 250 mL/hr require a CADD® high volume administration set.

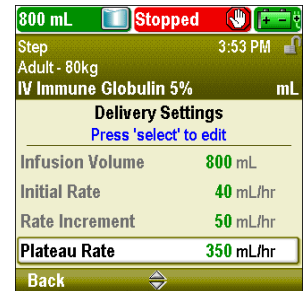

Step Duration

This is the length of time programmed for each step during medication delivery. After infusion occurs for the step duration, the rate increases by the rate increment unless the current rate is equal to the plateau rate.

Entering a new step duration resets the infusion so that delivery starts at the beginning.

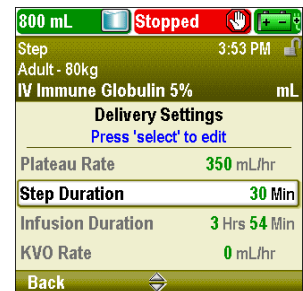

Infusion Duration

This is the time required to deliver the infusion volume. It is calculated by the pump based on the initial values programmed for infusion volume, initial rate, rate increment, step duration, and plateau rate. It appears on the screen for review only. Using Step Up or Step Down from the Advanced Tasks menu will change the actual infusion duration, although the displayed value will not change.

KVO Rate

The KVO or “keep vein open” rate is optional. It allows the delivery of a minimal amount of drug to help maintain catheter patency.

If a delayed start is programmed, the KVO rate is active until the infusion begins. It is also active after the infusion volume is delivered if the reservoir volume is programmed greater than the infusion volume.

Reservoir Vol.

This is the volume of fluid contained in the reservoir. The reservoir volume value decreases as the pump is primed or delivers fluid. *The reservoir volume should not be programmed or edited to be less than the programmed infusion volume.* If the reservoir volume is programmed to be less than the infusion volume, the pump will stop before it has infused the programmed infusion volume. To complete delivery of the programmed infusion volume a new reservoir volume must be entered. *Entering a new reservoir volume resets the infusion so that delivery starts at the beginning.*

If KVO delivery is intended at the end of the infusion, the reservoir volume must be larger than the infusion volume to compensate for fluid used for priming, and so that automatic KVO delivery may occur. KVO delivery continues until the reservoir volume reaches 0 mL or until the pump is stopped. If the reservoir volume is the same as the infusion volume, KVO delivery will not occur at the completion of the infusion.

Start Time

If Set Delayed Start is programmed (see page 33) then Start Time is displayed. This is the time that the next infusion will begin. The pump must be running on the selected date and time in order for delivery to begin. ***In Step therapy you may not set a delayed start after an infusion has started.***

800 mL	Stopped	3:53 PM
Step Adult - 80kg		
IV Immune Globulin 5% mL		
Delivery Settings Press 'select' to edit		
Plateau Rate	350 mL/hr	
Step Duration	30 Min	
Infusion Duration	3 Hrs 54 Min	
KVO Rate	0 mL/hr	
Back		

800 mL	Stopped	3:53 PM
Step Adult - 80kg		
IV Immune Globulin 5% mL		
Delivery Settings Press 'select' to edit		
Plateau Rate	350 mL/hr	
Step Duration	30 Min	
Infusion Duration	3 Hrs 54 Min	
KVO Rate	0 mL/hr	
Back		

800 mL	Stopped	3:53 PM
Step Adult - 80kg		
IV Immune Globulin 5% mL		
Delivery Settings Press 'select' to edit		
Infusion Duration	3 Hrs 54 Min	
KVO Rate	0 mL/hr	
Reservoir Vol.	800 mL	
Start Time	4:05 PM	
Back		

800 mL	Stopped	3:53 PM
Step Adult - 80kg		
IV Immune Globulin 5% mL		
Delivery Settings Press 'select' to edit		
Infusion Duration	3 Hrs 54 Min	
KVO Rate	0 mL/hr	
Reservoir Vol.	800 mL	
Start Time	4:05 PM	
Back		

Programming Example

(using a PharmGuard® Software Enabled pump with a customized drug library)

WARNING: Ensure that the $\pm 6\%$ system delivery accuracy specification is taken into account when programming the pump and/or filling the reservoir. Failure to do so may result in medication in the reservoir becoming depleted sooner than expected. If the pump is used to deliver critical or life-sustaining medication, the interruption in the delivery of medication could result in patient injury or death.

Example: A total of 700 mL of medication must be delivered to the patient. The initial dose must be given at 30 mL/hr, stepping up by 50 mL/hr in 30 minute increments until a plateau rate of 350 mL/hr is reached.

1. Select the Therapy

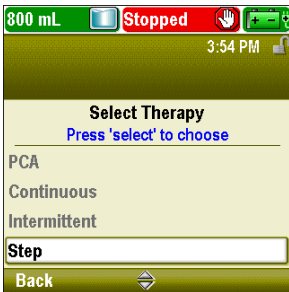

- Stop the pump if it is running.
- Select **Tasks**, then **View Advanced Tasks**, and then **Start New Patient**.
- Unlock the keypad.
- Press **▲** or **▼** to highlight the **Step** therapy and press **select**. See *Start New Patient* on page 29 if you need more information on selecting the therapy.

2. Select the Qualifier

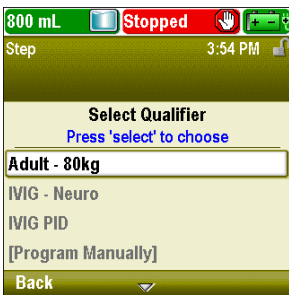

- Press **▲** or **▼** to highlight the desired qualifier and press **select**.

3. Select the Drug

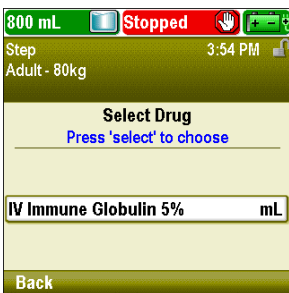

- Press **▲** or **▼** to highlight the desired drug, and press **select**.

4. Confirm and Review the Settings

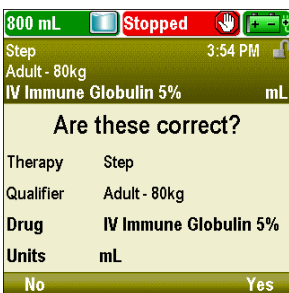

- Review the information on the screen and select **Yes** if they are correct, or **No** to edit the settings.

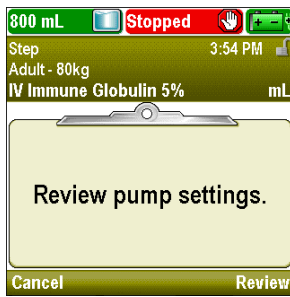

- The pump displays the **Review pump settings** screen. Select **Review** to continue.

5. Enter the Infusion Volume

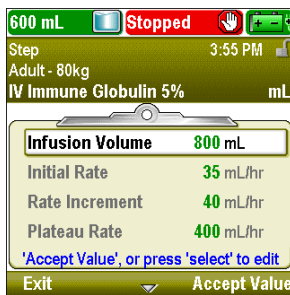

- Press \uparrow or \downarrow to highlight **Infusion Volume**. If the value shown is set at the desired volume, select **Accept Value** and go to step 6. If the value shown does not show the desired volume, press **select**.

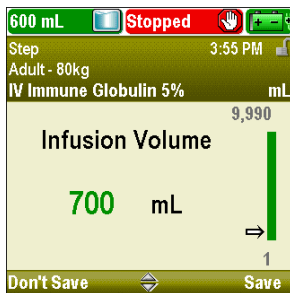

- Press \uparrow or \downarrow until the value reads **700 mL** and select **Save**.

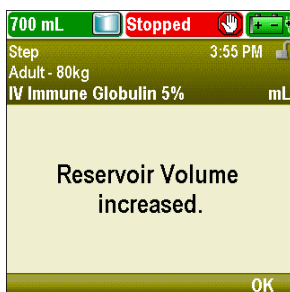

- If the infusion volume is greater than the displayed reservoir volume, you will be asked to confirm the change in the reservoir volume by selecting **OK**.
- The pump returns to the Review screen.

6. Enter the Initial Rate

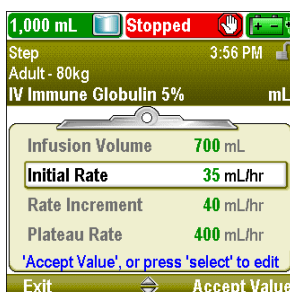

- Press \uparrow or \downarrow to highlight **Initial Rate**. If the value shown is set at the desired rate, select **Accept Value** and go to step 7. If the value shown does not show the desired rate, press **select**.

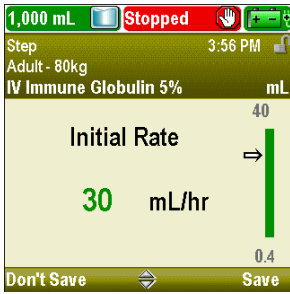

- Press **▲** or **▼** until the value reads **30 mL/hr** and select **Save**. The pump then returns to the Review screen.

7. Enter the Rate Increment

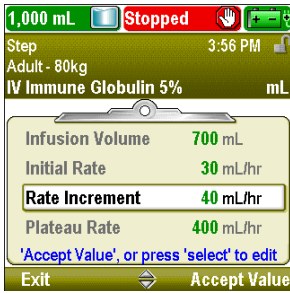

- Press **▲** or **▼** to highlight **Rate Increment**. If the value shown is set at the desired increment, select **Accept Value** and go to step 8. If the value shown does not show the desired increment, press **select**.

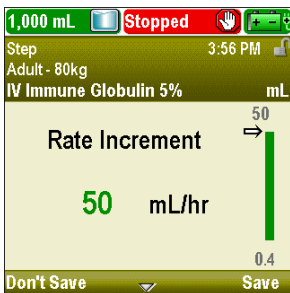

- Press **▲** or **▼** until the value reads **50 mL/hr** and select **Save**.
- The pump then returns to the Review screen.

8. Enter the Plateau Rate

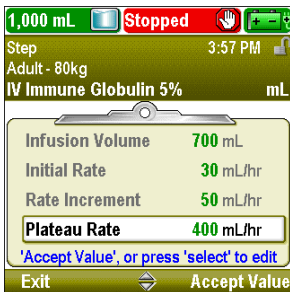

- Press **▲** or **▼** to highlight **Plateau Rate**. If the rate shown is correct, select **Accept Value** and go to step 9. If the value is not correct, press **select**.



- Press **▲** or **▼** until the value reads **350 mL/hr** and select **Save**.
- The pump then returns to the Review screen.

9. Enter the Step Duration

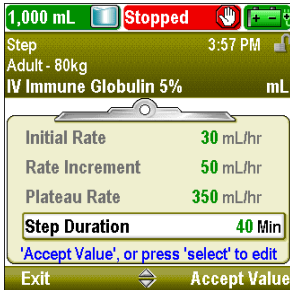

- Press **▲** or **▼** to highlight **Step Duration**. If the value shown is correct, select **Accept Value** and go to step 10. If the value is not correct, press **select**.

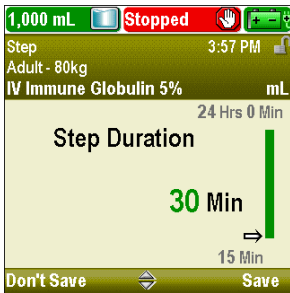

- Press **▲** or **▼** until the value reads **30 Min** and select **Save**.
- The pump then returns to the Review screen.

10. Review the Infusion Duration

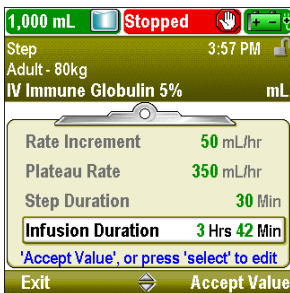

- Infusion Duration is a calculated value and cannot be edited.

11. Enter the KVO Rate

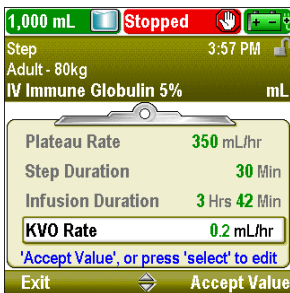

- Press **▲** or **▼** to highlight **KVO Rate**. If the value shown is correct, select **Accept Value** and go to step 12. If the value is not correct, press **select**.

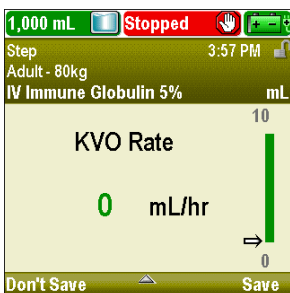

- Press **▲** or **▼** until the value reads **0 mL/hr** and select **Save**.
- The pump then returns to the Review screen.

12. Enter the Reservoir Volume

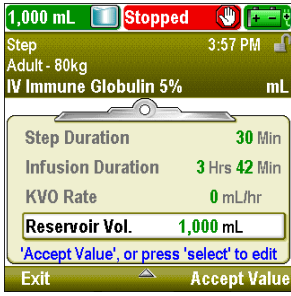

- Press **▲** or **▼** to highlight **Reservoir Vol.** If the value shown is correct, select **Accept Value** and go to step 13. If the value is not correct, press **select**.

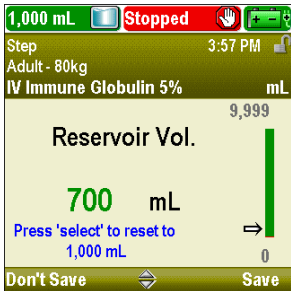

- Press **▲** or **▼** until the value reads **700 mL** and select **Save**.
- You may press **select** to reset the pump to a default amount which appears on the screen in blue text under the current value. In this example, pressing **select** resets the reservoir volume to 1,000 mL.
- The pump then returns to the Review screen.

13. Accept Values

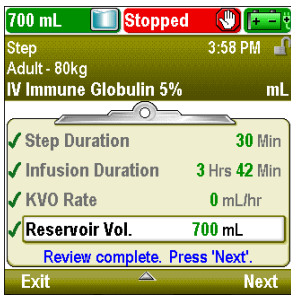

- If any values have not already been accepted, press **▲** or **▼** to highlight each setting and select **Accept Value** if the setting is correct. A green check mark appears next to each accepted value.
- After your review is complete, select **Next**.

14. Prepare the Pump for the Patient

- Follow the instructions for attaching a cassette, priming, and attaching the pump to the patient in *Operating the Pump* on page 80.

Starting Each infusion

When a new cassette is attached to the pump at the beginning of infusion, the reservoir volume should be reset. **This also resets the infusion.** Follow the instructions in *Operating the Pump* beginning on page 80, for attaching a cassette and resetting the reservoir. When the pump is started, delivery will start at the beginning of the infusion.

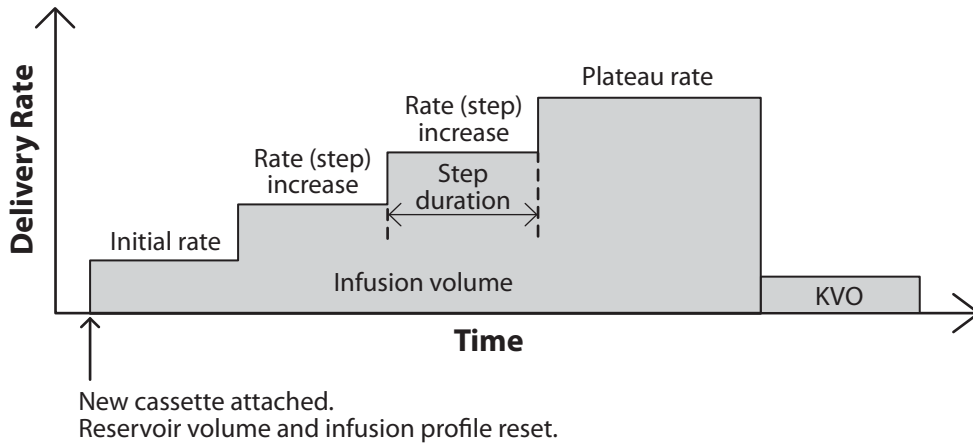

STEP

Stopping and Restarting the Pump During an Infusion

If you stop the pump before a step infusion was fully delivered, you may choose to either restart the infusion from where delivery left off, or you may reset the infusion.

When you press stop/start , a screen appears with the message, “Infusion was interrupted before completion. Finish interrupted infusion or start from beginning with new bag.” Select **New Bag** to reset the reservoir volume and reset the infusion. Or, select **Finish** to resume the infusion from the point it was at when it was last running.

Step Up

This option allows you to increase the rate of infusion at a time other than what is programmed. You cannot step up to a higher rate than the plateau rate.

To step up from the current rate:

1. In the Advanced Tasks menu, press  or  to highlight **Step Up** and press .

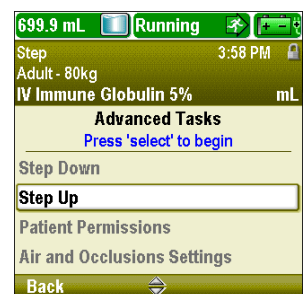

2. Unlock the keypad.
3. The pump displays a screen that tells you the current rate, and asks you if you want to step up to the next step rate. Select **Yes**.

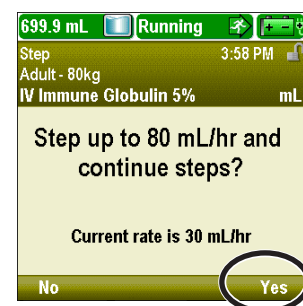

Step Down

This option allows you to reduce the rate of infusion at any time. You cannot step down lower than the initial rate. Once the step down task has been performed successfully, the automatic step increases after each step duration are cancelled. Delivery continues at the step down (hold) rate. The step up task can be used to restart the automatic step increases.

To step down from the current rate:

1. In the Advanced Tasks menu, press  or  to highlight **Step Down** and press .

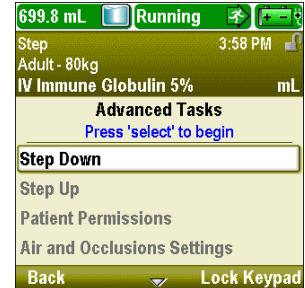

2. The pump displays a screen that tells you the current rate, and asks you if you want to step down to the previous step rate. Select **Yes**.

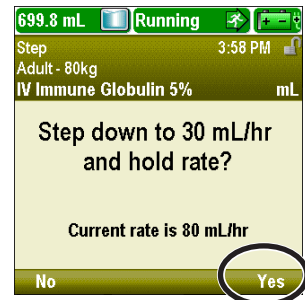

Taper Delivery Mode

Taper delivery allows the infusion of nutritional solutions (TPN, total parenteral nutrition) or other fluids, with optional tapering. Delivery can be gradually increased, or tapered up, at the beginning of the infusion, and it can be gradually decreased, or tapered down, at the end of the infusion. An optional KVO (keep vein open) rate may be delivered at the end of the infusion, depending on protocol settings.

The following graph illustrates an example taper delivery:

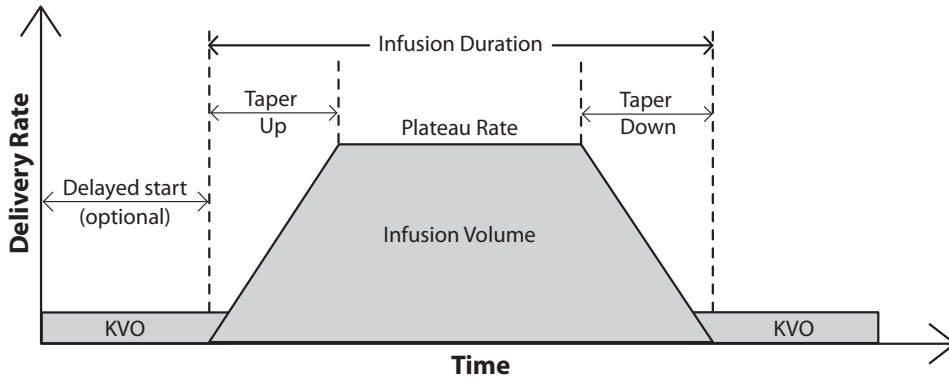

TAPER

Home Screen

The delivery mode and status of the infusion are indicated on the home screen with messages appearing in text, a graphic in a shape unique to the therapy, and with the colors green, red, and gray. The colors indicate that the pump is running (green), or stopped (red). If a new patient or new infusion is programmed but *the pump has not been started*, or if a delayed start time was programmed and the start time passed while the pump was stopped and not yet started, the graphic is entirely gray. The location of the color on the graphic also indicates the status of the infusion. The graphic used for taper delivery also identifies if taper up and/or taper down are programmed as part of the delivery setting. The examples below are specific to the taper delivery mode.

- The pump is running at the KVO rate with a programmed delayed start.
- The pump is stopped at the plateau rate.
- The pump is running at the plateau rate. No taper up was programmed.
- The pump is running at taper up.
- The pump is running at taper down.
- The pump is running at the KVO rate, nearing the end of the infusion.

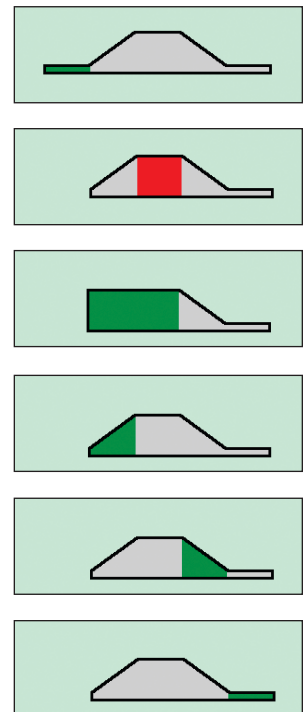

Taper delivery mode graphics do **not** depict the relative slope of the taper or the relative duration of the tapers in comparison to the plateau.

Programming Screens

Infusion Volume

This is the total volume of fluid to be delivered. If you enter an infusion volume that causes the plateau rate to exceed the maximum allowable rate, the pump automatically lengthens the infusion duration to accommodate the new volume. Additionally, the reservoir volume must be large enough to support the entire infusion volume. Therefore, programming the infusion volume may result in an automatic increase of the reservoir volume.

Entering a new infusion volume resets the infusion so that delivery starts at the beginning.

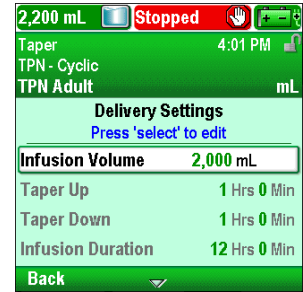

Taper Up

This is the duration for the taper up period. The maximum programmable taper up is limited by a combination of the plateau rate, infusion duration, infusion volume, and taper down. You cannot select a taper up duration that would cause the plateau rate to exceed the maximum allowable rate. In addition, the infusion duration must be at least 10 minutes more than the combined total of the taper up and taper down periods. Therefore, changing taper up may result in the pump automatically lengthening the infusion duration to accommodate the new taper up duration. *Entering a new taper up duration resets the infusion so that delivery starts at the beginning.*

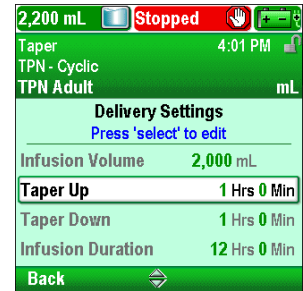

Taper Down

This is the duration for the taper down period. The maximum programmable taper down is limited by a combination of the plateau rate, infusion duration, infusion volume, and taper up. You cannot select a taper down duration that would cause the plateau rate to exceed the maximum allowable rate. In addition, the infusion duration must be at least 10 minutes more than the combined total of the taper up and taper down periods. Therefore, changing taper down may result in the pump automatically lengthening the infusion duration to accommodate the new taper down duration. *Entering a new taper down duration resets the infusion so that delivery starts at the beginning.*

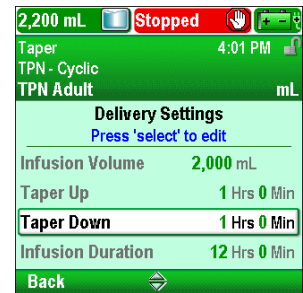

Infusion Duration

This is the time required to deliver the infusion volume. The pump automatically calculates the rate necessary to deliver the infusion volume. The minimum programmable infusion duration is limited by a combination of the plateau rate, infusion volume, taper up, and taper down. You cannot select an infusion duration that would cause the plateau rate to exceed the maximum allowable rate. In addition, the infusion duration must be at least 10 minutes more than the combined total of the taper up and taper down periods. *Entering a new infusion duration resets the infusion so that delivery starts at the beginning.*

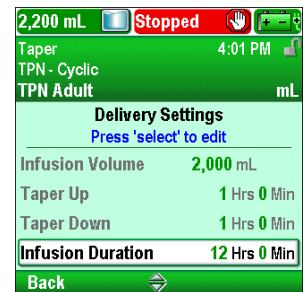

Plateau Rate

This is the maximum rate at which medication is delivered during the plateau portion of the infusion. It appears on the screen for review only and is calculated by the pump. The plateau rate is based on the infusion volume, infusion duration, and any programmed tapering. Rates above 250 mL/hr require a CADD® high volume administration set.

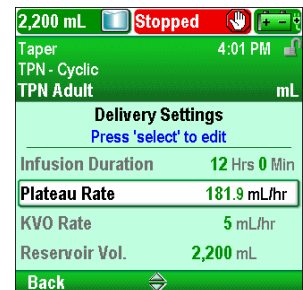

KVO Rate

The KVO or “keep vein open” rate is optional. It allows the delivery of a minimal amount of drug to help maintain catheter patency. If a delayed start is programmed, the KVO rate is active until the infusion begins. It is also active after the infusion volume is delivered if the reservoir volume is programmed greater than the infusion volume.

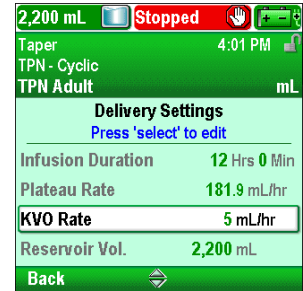

Reservoir Vol.

This is the volume of fluid contained in the reservoir. The reservoir volume value decreases as the pump is primed or delivers fluid. *The reservoir volume should not be programmed or edited to be less than the programmed infusion volume.* If the reservoir volume is programmed to be less than the infusion volume, the pump will stop before it has infused the programmed infusion volume. To complete delivery of the programmed infusion volume a new reservoir volume must be entered. *Entering a new reservoir volume resets the infusion so that delivery starts at the beginning.*

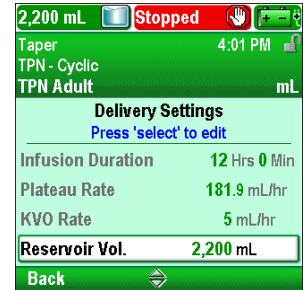

If KVO delivery is intended at the end of the infusion, the reservoir volume must be larger than the infusion volume to compensate for fluid used for priming, and so that automatic KVO delivery may occur. KVO delivery continues until the reservoir volume reaches 0 mL or until the pump is stopped. If the reservoir volume is the same as the infusion volume, KVO delivery will not occur at the completion of the infusion.

Start Time

If Set Delayed Start is programmed (see page 33) then Start Time is displayed. This is the time that the next infusion will begin. The pump must be running on the selected date and time in order for delivery to begin.

In Taper therapy you may not set a delayed start after an infusion has started.

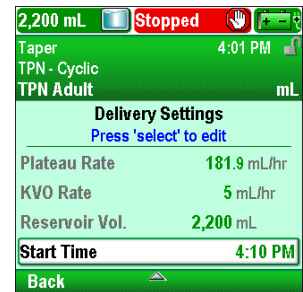

TAPER

Programming Example

(using a PharmGuard® Software Enabled pump with a customized drug library)

WARNING: Ensure that the $\pm 6\%$ system delivery accuracy specification is taken into account when programming the pump and/or filling the reservoir. Failure to do so may result in medication in the reservoir becoming depleted sooner than expected. If the pump is used to deliver critical or life-sustaining medication, the interruption in the delivery of medication could result in patient injury or death.

Example: A total of 1 L of TPN solution must be delivered to the patient over 12 hours. The TPN bag contains 1050 mL of solution. Delivery must taper up over 90 minutes at the beginning of the delivery, and taper down over 90 minutes at the end of delivery.

1. Select the Therapy

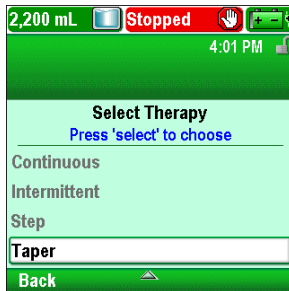

- Stop the pump if it is running.
- Select **Tasks**, then **View Advanced Tasks**, and then **Start New Patient**.
- Unlock the keypad.
- Press **▲** or **▼** to highlight the **Taper** therapy and press **select**. See *Start New Patient* on page 29 if you need more information on selecting the therapy.

2. Select the Qualifier

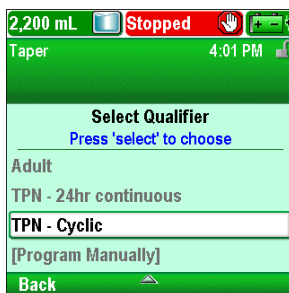

- Press **▲** or **▼** to highlight the desired qualifier and press **select**.

3. Select the Drug

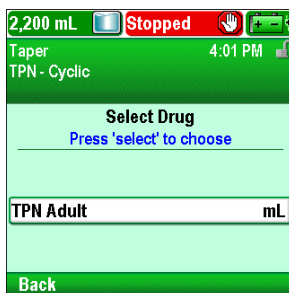

- Press **▲** or **▼** to highlight the desired drug, and press **select**.

4. Confirm and Review the Settings



- Review the information on the screen and select **Yes** if they are correct, or **No** to edit the settings.



- The pump displays the **Review pump settings** screen. Select **Review** to continue.

5. Enter the Infusion Volume

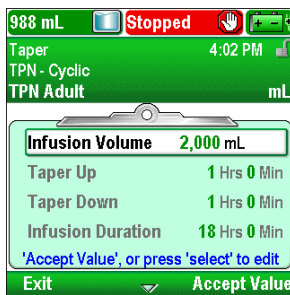

- Press **▲** or **▼** to highlight **Infusion Volume**. If the volume shown is set at the desired value, select **Accept Value** and go to step 6. If the value shown does not show the desired volume, press **select**.



- Press **▲** or **▼** until the value reads **1,000 mL** and select **Save**.

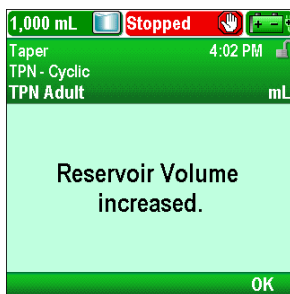

- If the infusion volume is greater than the displayed reservoir volume, you will be asked to confirm the change in the reservoir volume by selecting **OK**.
- The pump returns to the Review screen.

6. Enter Taper Up

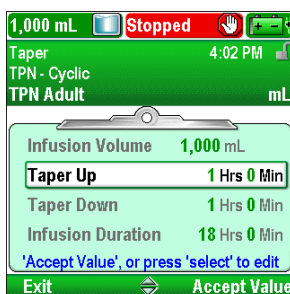

- Press **▲** or **▼** to highlight **Taper Up**. If the value shown is correct, select **Accept Value** and go to step 7. If the value shown is not correct, press **select**.



- Press **▲** or **▼** until the value reads **1 Hrs 30 Min** and select **Save**. The pump then returns to the Review screen.

7. Enter Taper Down

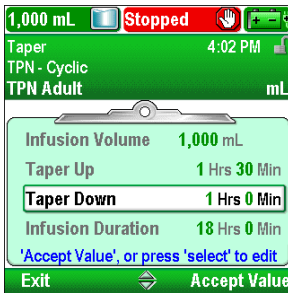

- Press **▲** or **▼** to highlight **Taper Down**. If the value shown is correct, select **Accept Value** and go to step 8. If the value shown is not correct, press **select**.

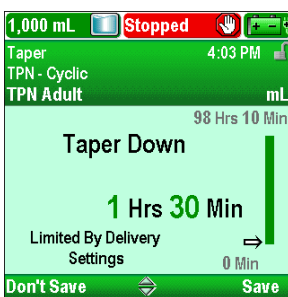

- Press **▲** or **▼** until the value reads **1 Hrs 30 Min** and select **Save**. The pump then returns to the Review screen.

8. Enter the Infusion Duration



- Press **▲** or **▼** to highlight **Infusion Duration**. If the value shown is correct, select **Accept Value** and go to step 9. If the value shown is not correct, press **select**.

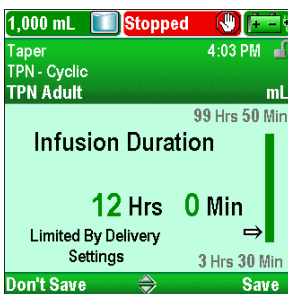

- Press **▲** or **▼** until the duration reads **12 Hrs 0 Min** and select **Save**.
- The pump then returns to the Review screen.

9. Review the Plateau Rate

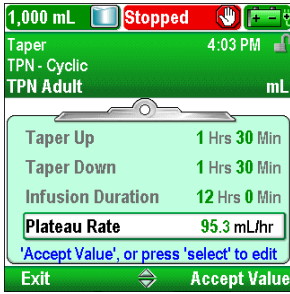

- The plateau rate is a calculated value and cannot be edited.

10. Enter the KVO Rate

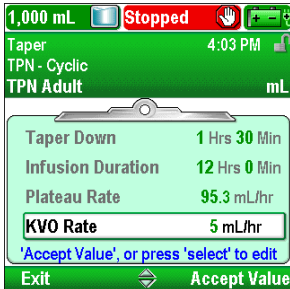

- Press **▲** or **▼** to highlight **KVO Rate**. If the value shown is correct, select **Accept Value** and go to step 11. If the value is not correct, press **select**.



- Press **▲** or **▼** until the value reads **0 mL/hr** and select **Save**.
- The pump then returns to the Review screen.

11. Enter the Reservoir Volume

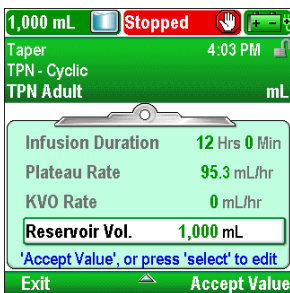

- Press **▲** or **▼** to highlight **Reservoir Vol.** If the value shown is correct, select **Accept Value** and go to step 12. If the value is not correct, press **select**.



- Press **▲** or **▼** until the value reads **1,050 mL** and select **Save**.
- You may press **select** to reset the pump to a default amount which appears on the screen in blue text under the current value. In this example, pressing **select** resets the reservoir volume to 1,000 mL.
- The pump then returns to the Review screen.

12. Accept Values

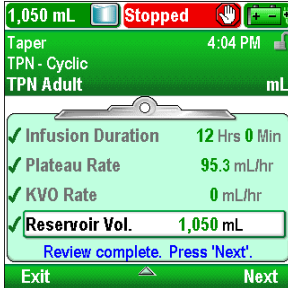

- If any values have not already been accepted, press \blacktriangle or \blacktriangledown to highlight each setting and select **Accept Value** if the setting is correct. A green check mark appears next to each accepted value.
- After your review is complete, select **Next**.

13. Prepare the Pump for the Patient

- Follow the instructions for attaching a cassette, priming, and attaching the pump to the patient in *Operating the Pump* on page 80.

Starting Daily Infusion

When a new cassette is attached to the pump at the beginning of infusion, the reservoir volume should be reset. **This also resets the infusion.** Follow the instructions in *Operating the Pump* beginning on page 80), for attaching a cassette and resetting the reservoir. Then when the pump is started, delivery will start at the beginning of the infusion.

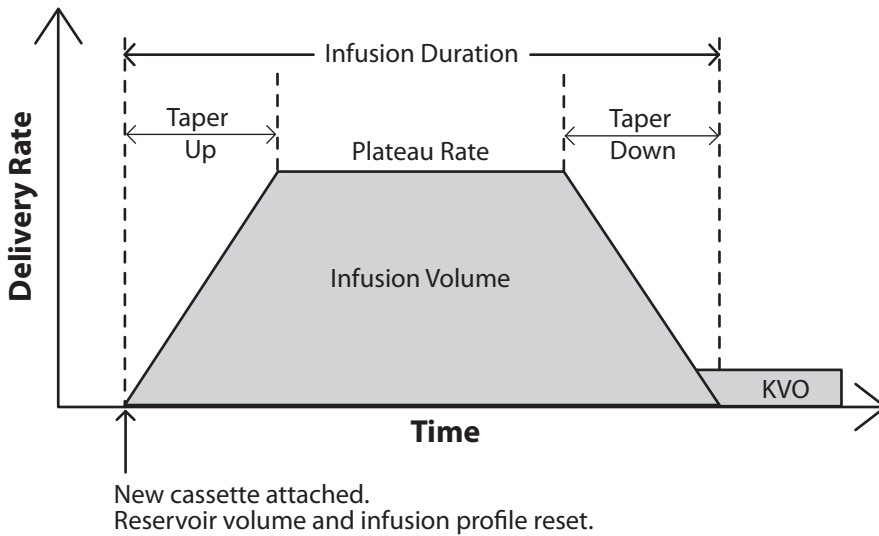

Stopping and Restarting the Pump During an Infusion

If you stop the pump before a taper infusion was fully delivered, you may choose to either restart the infusion from where delivery left off, or you may reset the infusion.



When you press stop/start ⏸ , a screen appears with the message, “Infusion was interrupted before completion. Finish interrupted infusion or start from beginning with new bag.” Select **New Bag** to reset the reservoir volume and reset the infusion. Or, select **Finish** to resume the infusion from the point it was at when it was last running.



Taper Down Now

This task allows you to stop an infusion early by immediately tapering down. The following conditions are necessary for Taper Down Now:

- The pump must be running.
- The pump must be delivering at the plateau rate or already be in taper down.

To access the Taper Down Now option:

1. From the Tasks menu (see page 141), press  or  until **Taper Down Now** is highlighted, and then press .

Note: If a taper down was not programmed, you can edit the setting by pressing . Enter the security code, and then press  or  to set the taper down duration. Select **Confirm** to accept the change.

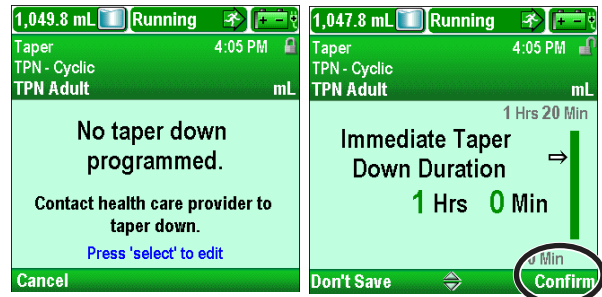

2. Select **Yes** to continue with taper down now or press  to edit the taper down period. Editing the taper down now period only affects the period for this immediate taper. It has no effect on the taper period of the protocol that is seen in the delivery settings.

Note: Once you select **Yes**, you can *not* restart delivery at the plateau rate without resetting the infusion period.

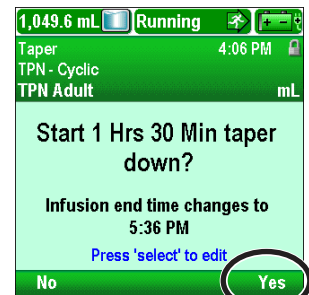

3. When “Beginning Taper Down...” appears, select **OK**.



Operating the Pump

Batteries

Four AA, 1.5 volt primary (non-rechargeable) alkaline batteries (for example, Duracell® PC1500/MN1500, IEC LR6) or the CADD®-Solis rechargeable battery pack are recommended for use in the CADD®-Solis VIP ambulatory infusion pump.

Note: Smiths Medical does not recommend mixing new and used batteries because it may affect low battery alarm times. Always use 4 new batteries when replacing depleted ones.

CAUTION: Inspect the AA batteries for damage or wear to the metal or plastic insulation prior to use, or after the pump has been dropped or hit. Replace the batteries if any damage is noted.

The pump retains all programmed values when the batteries are removed, but the batteries must be in place during delivery. If the batteries are removed while the pump is delivering, and an AC adapter is connected, delivery stops. If an AC adapter is not connected and the batteries are removed, delivery stops and the pump loses power.

Dispose of used batteries in an environmentally safe manner, and according to any regulations which may apply.

WARNING:

- Do not use rechargeable NiCd or nickel metal hydride (NiMH) batteries. Do not use carbon zinc ("heavy duty") batteries. They do not provide sufficient power for the pump to operate properly, which could result in death or serious injury to the patient.
 - Always have new batteries available for replacement. If power is lost, nondelivery of drug occurs and depending on the type of drug being administered, could result in death or serious injury to the patient.
 - A rechargeable battery pack that has reached the end of its useful life must be replaced with either another CADD®-Solis rechargeable battery pack or with 4 AA batteries. Using rechargeable battery packs from other manufacturers could result in fire or explosion.
 - There is no pump alarm to alert users that a battery has not been properly installed. An improperly installed battery could result in loss of power and nondelivery of drug and depending on the type of drug being administered, could result in death or serious injury to the patient.
 - Always check the battery compartment for fluid or debris before inserting the batteries, and do not allow any fluid or debris to fall into the battery compartment. Fluid or debris in the battery compartment may damage the battery contacts and could result in loss of power and nondelivery of drug and depending on the type of drug being administered, could result in death or serious injury to the patient.
 - If the pump is dropped or hit, the battery door may become broken or damaged. Do not use the pump if the battery door is damaged because the batteries will not be properly secured. This may result in loss of power, nondelivery of drug and depending on the type of drug being administered, could result in death or serious injury to the patient.
-

Install the Batteries or Battery Pack

1. Make sure the pump is stopped and powered off. Using your fingers, the pump key, or a coin, turn the knob on the battery door counterclockwise to open the battery door.

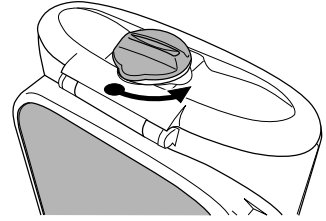

2. Hold the pump at an angle and place 4 AA batteries in the pump, from the bottom up (see picture). Match the + and – markings on the new batteries with the markings on the pump.

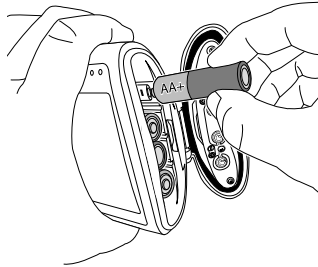

OR: If using a rechargeable battery pack, insert it into the pump as shown.

OR

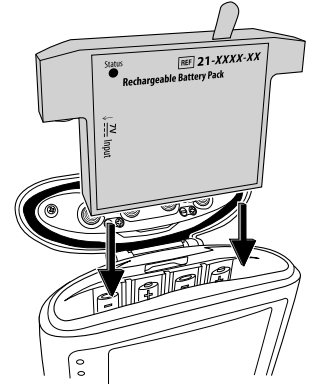

3. Close the battery door and using your fingers, the pump key, or a coin, turn the knob on the battery door clockwise to lock.

Note: If you put the batteries in backwards, the pump will not power up. Check the batteries, making sure to match the + and – markings.

CAUTION: Do not store the pump for prolonged periods with the batteries installed. Battery leakage could damage the pump.

Note:

- Battery life is dependent on the amount of medication delivered, delivery rate, battery age, temperature, active display time, and backlight intensity.
- Battery power is quickly depleted at temperatures below 10°C (50°F).

Replace the Battery Door

If the battery door is removed or needs replacing, simply snap the door onto the bar that is located on the pump.

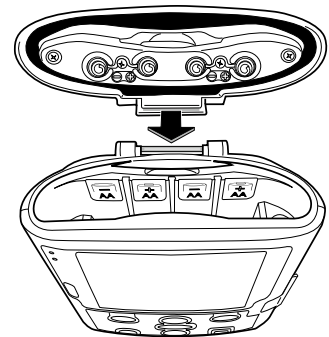

Power Up

Press and hold the power switch to turn the pump on. The pump starts the power up sequence during which it performs various self-tests, and tests for alarm conditions. Watch for the following during power-up:

- Both the green and amber indicator lights flash.
- The display quickly flashes gray, then blue. An amber swirl then fills the display, followed by a CADD®-Solis VIP Ambulatory Infusion System display. Look for any stripes or black or white pixels which indicate a faulty display. If you see any indication of a faulty display, remove the pump from service and contact Smiths Medical Customer Service.
- After the power up is completed, listen for the Morse Code “OK” sound (a series of six audible beeps). If you do not hear this sound, there may be a problem with the audible alarms. If you believe there is a problem, remove the pump from service and contact Smiths Medical Customer Service.
- If any issues are found while the pump is performing the self tests, alarms will sound (for example, if the battery is low or a key on the keypad is stuck in the pressed position).

CAUTION: If the power up results in an error message indicating that the protocol library was lost, do not proceed with using the pump. Follow your facility’s procedures for downloading protocol libraries.

- When powering up the pump, you can identify the pump configuration on the power up screen shown below.



Power Down

Press the power switch to turn the pump off. You must acknowledge the “Power down?” prompt by selecting **Yes**. The pump then powers down. Be aware of the following conditions when the pump is powered down:

- The display is blank.
- Keypad presses are not detected.
- The remote dose cord does not function.
- Medication is not infused.
- Alarm conditions are not sensed.
- Audio and visual alarms are not displayed.
- Communication with PharmGuard® Administrator Medication Safety Software is not possible.
- If the AC adapter is plugged in, the blue AC power light is on. No other lights are lit.
- The internal battery used to retain time and date does not charge.
- If the pump is connected to AC power and a rechargeable battery pack is installed, the battery pack continues to charge.

Cassettes

The cassette is the part of the CADD™ medication cassette reservoir or CADD® administration set that attaches to the bottom of the pump. Either a CADD™ medication cassette reservoir used with a CADD® extension set, or a CADD® administration set are compatible with the pump.

WARNING:

- Follow the instructions for use provided with the CADD™ medication cassette reservoir, CADD® extension set, or CADD® administration set, paying particular attention to all warnings and cautions associated with their use. Incorrect preparation and/or use of these products could result in serious patient injury or death.
- Carefully route tubing, cords, and cables to reduce the possibility of patient entanglement or strangulation. Failure to observe this warning could result in patient injury or death.

Note:

- A CADD® set with free flow protection must be used.
- A CADD® high volume administration set is required for rates above 250 mL/hr.
- An alarm will sound and the pump will not run if you attempt to use an administration set other than the type required by programmed parameters. Do not manually adjust the delivery rate to override pump programming without written authorization from the prescribing physician.
- Appropriate supplies needed to replace cassettes should be available if a cassette is damaged.
- For detailed instructions on preparing the product for use, refer to the instructions for use supplied with the product.

Remove a Cassette

1. Make sure the pump is stopped before removing the cassette.
2. Close the tubing clamp.

WARNING: Per general rules of safe practice, always clamp the tubing before removing the cassette from the pump. Removing the cassette without closing the clamp could potentially cause unregulated gravity infusion, which could result in patient injury or death.

3. If locked, insert the pump key and turn the cassette/keypad lock counter-clockwise into the unlocked position. "Cassette Unlocked" briefly appears in the status bar.

Note: Only PCA infusions require the cassette to be locked in order to run the pump.



4. Push down on the cassette latch until the cassette detaches.

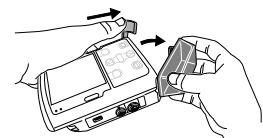

Attach a Cassette

WARNING: Attach the cassette properly. A detached or improperly attached cassette could result in unregulated gravity infusion of medication from the reservoir or a reflux of blood, which could result in death or injury to the patient.

If you are using a CADD® administration set or CADD™ medication cassette reservoir that does not have the Flow Stop feature, you must use a CADD® extension set with anti-siphon valve, or a CADD® administration set with either an integral or add-on anti-siphon valve to protect against unregulated gravity infusion that can result from an improperly attached cassette. Unregulated gravity infusion can result in death or serious injury.

CAUTION: If you are using a CADD™ medication cassette reservoir in which the medication is frozen, thaw at room temperature only. Do not heat in a microwave oven as this may damage the product and cause leakage.

Before attaching a new cassette, make sure the pump is powered on. Once the cassette is attached, the pump automatically displays screens that allow you to verify the cassette type, prime the fluid path, reset the reservoir volume, review pump settings, and/or start the pump.

1. Obtain a new, filled CADD™ medication cassette reservoir, or CADD® administration set attached to a flexible IV bag. Refer to the instructions for use supplied with the product for information on preparing the product for use.
2. Clamp the tubing.
3. Make sure the cassette latch is unlocked and open the cassette latch to 90 degrees.

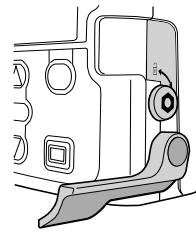

4. Insert the cassette hooks into the hinge pins on the bottom of the pump.

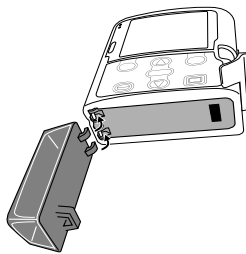

5. Without holding the cassette latch:

Push up on the cassette until it firmly clicks into place.

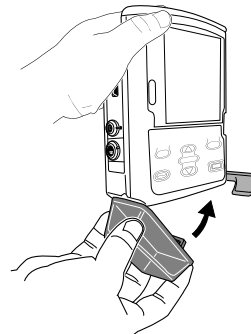

-OR-

Place the pump upright on a firm, flat surface, and then press down on the latch side of the pump until the cassette firmly clicks into place.

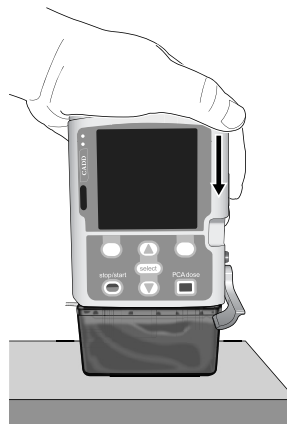

- Lift the cassette latch into the closed position. You should be able to move the latch into the closed position with minimal to no resistance. If you experience resistance when lifting the cassette latch, **DO NOT FORCE** the latch. If you are unable to attach the cassette to the pump with minimal to no resistance, the cassette is not in the proper latching position. If the pump does not latch easily, unlatch the cassette and repeat the process. If unsuccessful on the second attempt, do not use the pump. Contact Smiths Medical Customer Service for further assistance.

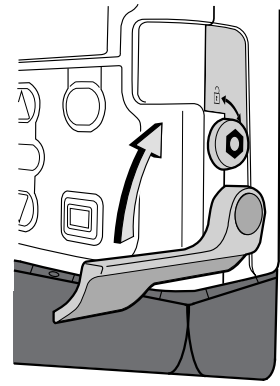

- Verify the cassette is attached correctly. Looking from left to right, the top of the cassette should line up evenly with the bottom of the pump and be securely attached. If the cassette is attached incorrectly, there will be an uneven gap between the cassette and the pump, with the gap appearing on the latch side of the pump. If an uneven gap exists, unlatch the cassette and repeat the process. If the gap exists after the second latch-up attempt, do not use the pump. Contact Smiths Medical Customer Service for further assistance.

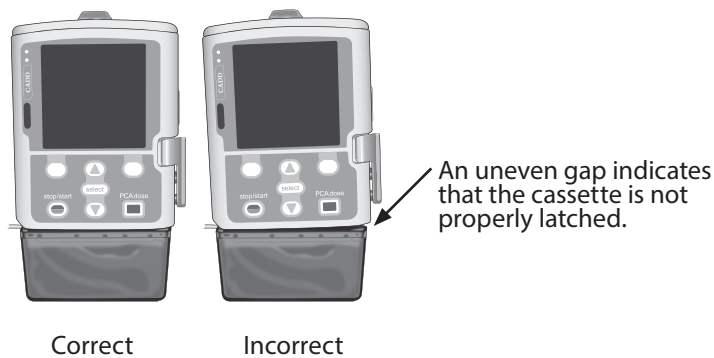

- A brief message appears on the pump screen so you can verify the type of cassette you have attached.
- If you wish to lock the cassette, insert the pump key into the cassette/keypad lock and turn clockwise into the locked position. "Cassette Locked" appears briefly in the status bar.

NOTE: For PCA infusions, the cassette must be locked in order to start the pump.

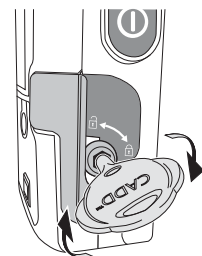

Prime Tubing

When priming the fluid path, the tubing downstream of the pump is filled with fluid, removing any air bubbles. Prime the tubing *before* connecting it to the patient’s infusion set or indwelling catheter.

Fluid delivered by priming is subtracted from the reservoir volume, but is not added to the amount given because this fluid is not delivered to the patient. Priming is not allowed when the reservoir volume is 0 mL.

Note:

- The air detector is disabled while the pump is priming.
- If the fluid path contains an air eliminating filter, it is acceptable for air bubbles to be present on the vent side of the filter. See the instructions for use supplied with the disposable sets for more information.

Prime Tubing After Changing a Cassette

Note: If you are not changing the cassette but wish to prime the fluid path, use the *Prime Tubing, No Cassette Change* task described on page 87.

1. When a cassette is attached after the pump is powered on, a “Prime tubing?” screen always appears.

When *priming security* is set to *On* under patient permissions, a screen similar to the one on the right appears, and a security code is required to proceed. If you do not have permission to prime the tubing or if the tubing is pre-primed, select **No**. For additional information, see *Patient Permissions* on page 103.

If you have permission to prime the tubing, select **Yes**. Unlock the keypad.

When *priming security* is set to *Off* under patient permissions, a screen like the one to the right appears. Select **Yes**.

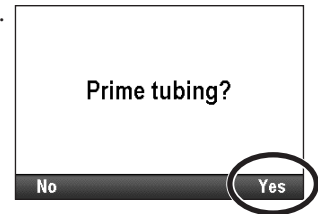
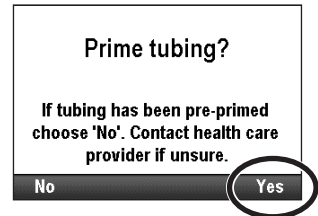

2. If you have not already done so, disconnect the tubing from the patient, open the clamps, select **Prime**.

Note: Turning the pump with latch facing down during priming is optional and may improve the removal of air from the cassette portion of the tubing.

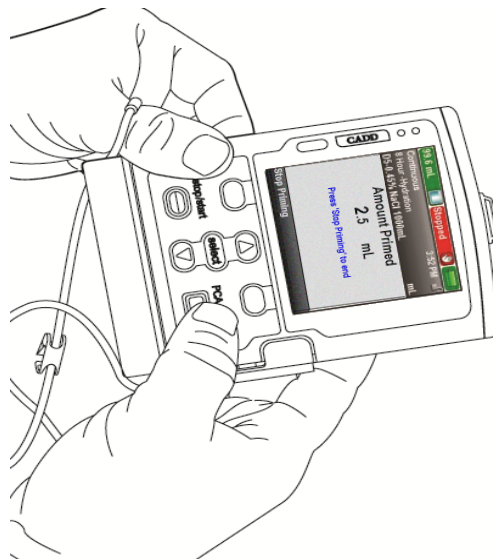
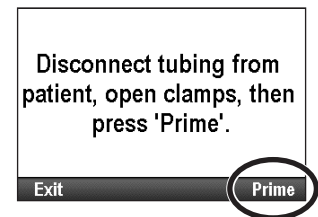

WARNING: Do not prime the fluid path with the tubing connected to a patient as this could result in overdelivery of medication or air embolism, which could result in serious patient injury or death.

- Stop priming at any time by selecting **Stop Priming**. Priming automatically stops after 10 mL (or 20 mL if a high volume set is attached) are primed. Continue priming as needed.

WARNING: To prevent air embolism, ensure that the entire fluid path is free of all air bubbles before connecting to the patient. Air embolism could result in serious patient injury or death.

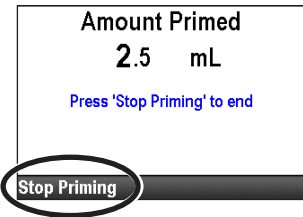

Prime Tubing, No Cassette Change

- Stop the pump if it is running.
- In the Tasks menu (see page 141), press or until **Prime Tubing** is highlighted, and then press .

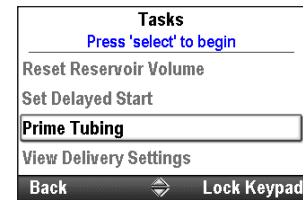

- Unlock the keypad, if required.
- If you have not already done so, disconnect the tubing from the patient, open the clamps, select **Prime**

Note: Turning the pump with latch facing down during priming is optional and may improve the removal of air from the cassette portion of the tubing.

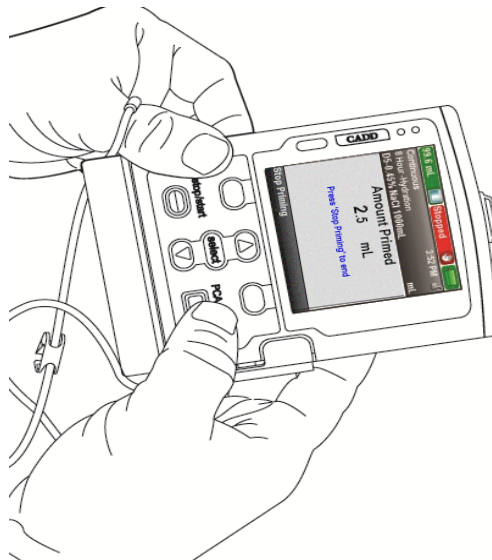
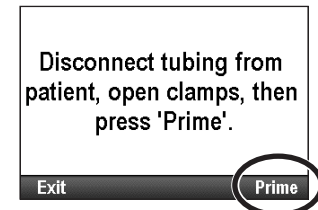

WARNING: Do not prime the fluid path with the tubing connected to a patient as this could result in overdelivery of medication or air embolism, which could result in serious patient injury or death.

- Stop priming at any time by selecting **Stop Priming**. Priming automatically stops after 10 mL (or 20 mL if a high volume set is attached) are primed. Continue priming as needed.

WARNING: To prevent air embolism, ensure that the entire fluid path is free of all air bubbles before connecting to the patient. Air embolism could result in serious patient injury or death.

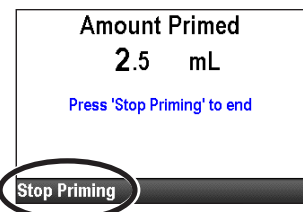

Start the Pump

Infusion begins when the pump starts. When the pump is running, “Running” appears on the status bar, the graphic on the home screen is green, and the green indicator light flashes. If the pump will not start, a message appears on the display. Refer to *Alarms and Messages* on page 113.

Note: Before starting the pump, be sure the tubing is primed and the pump is connected to the patient according to your facility’s standards of practice.

1. Press stop/start .

Note: If the delivery settings have not been reviewed and the values have not been accepted, you must do so before the pump will run. Instructions for reviewing settings are available on page 38.



If a step or taper infusion was previously stopped and delivery was not completed (the infusion was not fully delivered), a screen appears with the message, “Infusion was interrupted before completion. Finish interrupted infusion or start from beginning with new bag.” Select **New Bag** to reset the reservoir volume and reset the infusion. Or, select **Finish** to resume the infusion from the point it was at when it was last running.

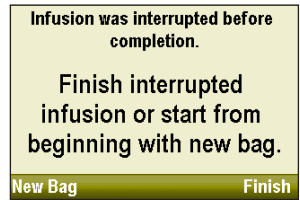

2. When “Start Pump?” appears, select **Yes**.

Note: To set a delayed start time, refer to *Delayed Start* on page 33 for all therapies except intermittent, or *Next Dose Start Time* on page 34 for intermittent therapies.

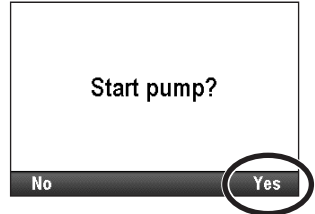

3. The pump begins running. The red “Stopped” message in the status bar changes to a green “Running” message, and “Infusion is starting now...” appears briefly on the screen.



If a delayed start was programmed, the display turns green and a message that the infusion is delayed appears briefly on the screen. Then the “Delayed Start” screen appears along with the time remaining until the infusion starts. The pump infuses at the programmed KVO rate.

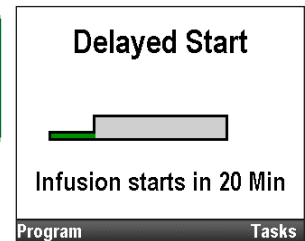

Stop the Pump

Stopping the pump stops delivery. After the pump is stopped, “Stopped” appears in red on the status bar, the graphic on the home screen is red, the amber indicator light flashes, and the green indicator light is off.

1. Press stop/start .

In a PCA protocol, if a PCA dose is in progress, “Stop PCA dose?” appears. Select **Yes** to stop the dose.

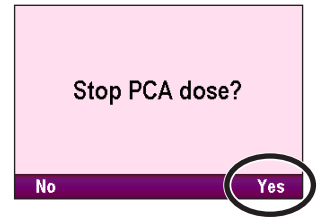

In a PCA protocol, if a clinician bolus is in progress, “Stop clinician bolus?” appears. Select **Yes** to stop the bolus. A confirmation screen appears stating, “Clinician bolus stopped.” Select **OK** to continue.

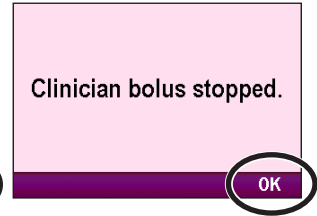
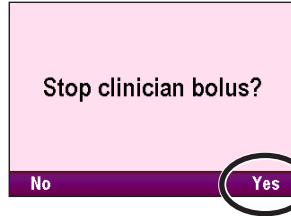

In a taper protocol, “Taper down instead?” appears. Select **No** to stop the infusion (see *Taper Down Now* on page 79 if you want to taper down rather than stop the pump).

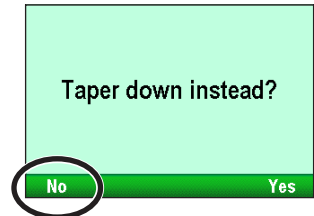

2. When “Stop Pump?” appears, select **Yes**.

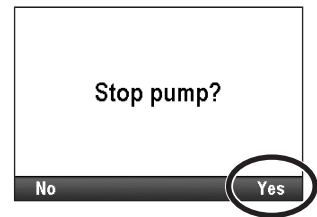

3. The pump stops running. The green “Running” message in the status bar changes to a red “Stopped” message, and “Pump is stopping...” appears briefly on the screen.



Reset Reservoir Volume

The reservoir volume setting indicates the amount of fluid contained in the reservoir. Once this number is set, the pump keeps track of how much fluid is delivered and adjusts the reservoir volume setting accordingly.

WARNING: Ensure that the $\pm 6\%$ system delivery accuracy specification is taken into account when programming the pump and/or filling the reservoir. Failure to do so may result in medication in the reservoir becoming depleted sooner than expected. If the pump is used to deliver critical or life-sustaining medication, the interruption in the delivery of medication could result in patient injury or death.

When you latch and/or lock a cassette onto the pump as described on page 84, a series of messages leads you through resetting the reservoir volume, priming the tubing, and starting the pump. You can, however, reset the reservoir volume without changing the cassette by using the Reset Reservoir Volume task.

The CADD[®]-Solis system administrator may set a standard reservoir volume for each therapy that allows you to quickly reset the reservoir volume to that value. To reset the reservoir volume to a quantity other than the default setting, refer to *Editing Delivery Settings* on page 37.

Note: If you are running a step or taper therapy, resetting the reservoir volume also resets the infusion. When you restart the pump, delivery starts at the beginning of the infusion duration.

To reset the reservoir volume after attaching a new cassette:

1. The pump displays a question asking if you wish to reset the volume to the default amount. If this screen does not appear, the reservoir volume may already be reset.

In this example, selecting **Yes** resets the volume to 1,000 mL.



2. If you are running a step or taper therapy, you also see, “Infusion will be reset.” Select **Yes** to reset the volume and infusion. Select **No** to keep the reservoir volume at the current setting.

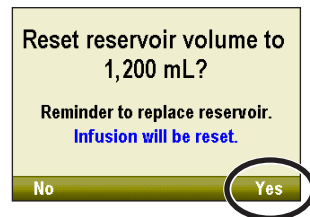

To reset the reservoir volume without changing the cassette:

1. Stop the pump if it is running.
2. In the Tasks menu (see page 141), press **▲** or **▼** until **Reset Reservoir Volume** is highlighted, and then press **select**.

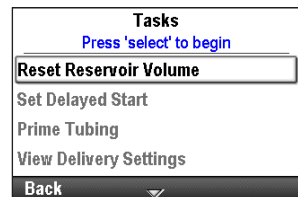

3. The pump displays a screen asking you to confirm that you want to reset the reservoir volume. Select **Yes**.



Tasks and Advanced Tasks

Tasks Menu Overview

The Tasks menu leads to most of the pump's operating functions. Some items on the Tasks menu are protected by the various security levels. To learn more about the security codes, refer to *Security Settings* on page 20.

The following functions are on the Tasks menu.

Task Menu Function	Description on Page
Reset Reservoir Volume	29
Taper Down Now (Taper therapy)	79
Set Delayed Start (all therapies except Intermittent)	33
Set Next Dose Start Time (Intermittent therapy)	34
Prime Tubing	86
View Delivery Settings	36
Display and Sound Settings	92
Change Time and Date	95
View Reports	98
View Advanced Tasks	83

To access the Tasks menu:

Select **Tasks** from the home screen.

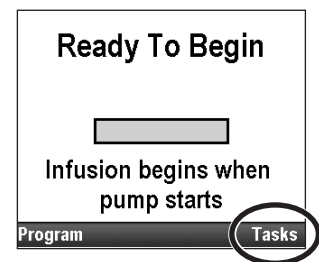

Display and Sound Settings

The Display and Sound Settings menu allows you to adjust various factors such as the intensity of the backlight on the screen, alarm volumes, sound themes, key beeps, and numeric formats. This change is for the current protocol only and remains in effect until the Start New Patient or Same Patient New Protocol task is selected.

In the Tasks menu, press  or  to highlight **Display and Sound Settings** and press .

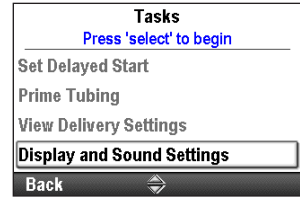





Backlight Intensity

The backlight intensity feature allows you to adjust the screen backlight intensity within the range of 1 to 10, with 1 being low and 10 being high.

Note: Increasing the backlight intensity shortens the battery life. For example, an increase of the backlight intensity from 5 to 10, reduces the battery life by 25%.

To adjust the backlight intensity:

- In the Display and Sounds Settings menu, press  or  to highlight **Backlight Intensity** and press .
- Press  or  to scroll from 1 to 10. The pump displays the intensity of each number as it appears. Once you have the desired backlight intensity, select **Save**.

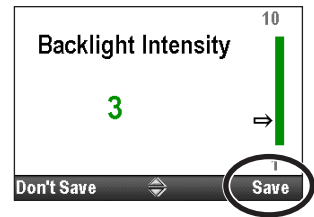
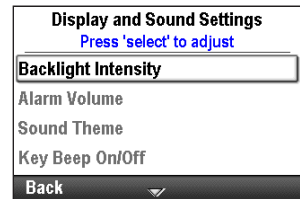

Alarm Volume

The alarm volume feature allows you to set the volume of the alarms in the therapy. You may choose between 3 volumes: low, medium, and high. Consider external noise sources when setting the alarm volume.

Note:

- Use of a pouch or backpack may muffle audible alarms.
- If a high or medium priority alarm exists for 2 minutes without being acknowledged, the alarm volume automatically adjusts to “High”.

To adjust the alarm volume:

- In the Display and Sounds Settings menu, press  or  to highlight **Alarm Volume** and press .

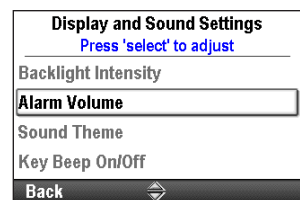

2. Press **▲** or **▼** to highlight **Low**, **Medium**, or **High**, and select **Save**.

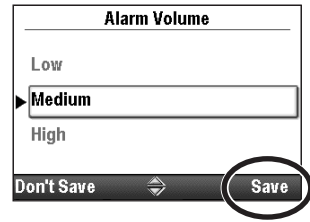

Sound Theme

The Sound Theme setting allows you to choose between 3 different sound themes for the alarms and beeps that the pump makes. The 3 themes are standard, intense, and distinctive. You may preview the sound themes in the menu. The alarms and beeps that use the sound theme:

- High Priority Alarm
- Medium Priority Alarm
- Low Priority Alarm
- Informational Alarm

To choose a sound theme:

1. In the Display and Sounds Settings menu, press **▲** or **▼** to highlight **Sound Theme** and press **select**.
2. Press **▲** or **▼** to highlight **Standard**, **Intense**, or **Distinctive**, and press **select** to preview the theme, or select **Save** to save the theme without a preview.
3. To preview the theme, press **▲** or **▼** to scroll through the alarms and beeps. Press **select** to listen to each alarm or beep. Continue until you have decided which one to apply. To exit, select **Back**.
4. Highlight the desired theme and select **Save**.

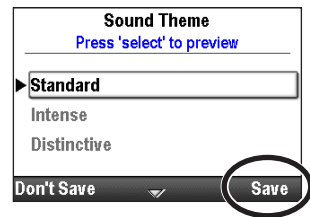
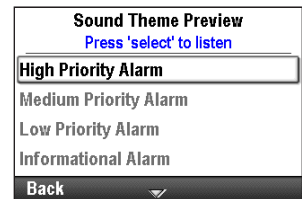
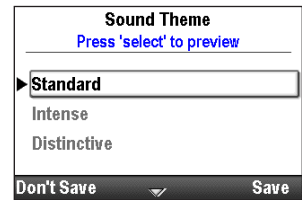
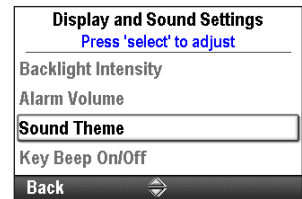





Key Beep On/Off

The key beep on/off feature allows you to turn on or off the audible beep that accompanies each key press. This feature **does not** turn off any audible alarms associated with alarm or alert conditions of the pump.

Note: If the key beep feature is turned on, the key beeps will not sound while any alarm screens are being displayed or when entering a security code.

To turn the key beeps on or off:

1. In the Display and Sounds Settings menu, press  or  to highlight **Key Beep On/Off** and press .
2. Press  or  to highlight **Off** or **On** and select **Save**.

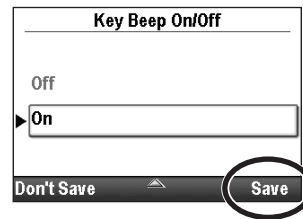
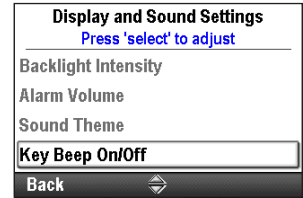





Numeric Format

The numeric format setting allows you to select the character or space used to indicate the decimal point and thousands units separators. Select the appropriate numeric format for your location, and follow the standard format used in your facility. The formats available are:

- 1,234.56
- 1.234,56
- 1 234.56
- 1 234,56

To modify the numeric format:

1. In the Display and Sounds Settings menu, press  or  to highlight **Numeric Format** and press .
2. Unlock the keypad.
3. Press  or  to highlight the format you want and select **Save**.

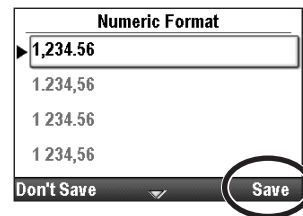
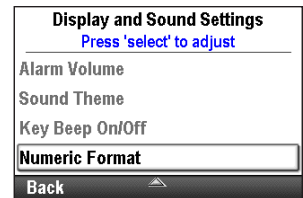

Time and Date

The Change Time and Date setting allows you to edit the time and date, and to choose a time and date format. The time and date options should reflect the current time and date, and follow the standard format used in your facility.

The clock is powered by a separate, internal battery, which retains the time and date even when the 4 AA batteries or the battery pack is removed. The pump uses this feature to record the time and date of events in the delivery and event logs, and in other reports. It is also used to determine when delayed starts and next dose start times begin, and when preventive maintenance alarms occur.

Note: The internal battery is rechargeable and automatically recharges when the pump is powered on. If the pump is off for a long period of time, it may not show the correct time and date when it is powered on. Check the time and date, and edit these settings if necessary.





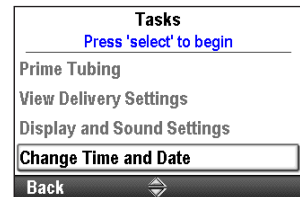







CAUTION: If delivery of an infusion is affected by a time or date change, an alarm message appears and must be confirmed.

In the Tasks menu, press  or  to highlight **Change Time and Date** and press .



Current Time

To set the current time:

- In the Set Time and Date menu, press  or  to highlight **Current Time** and press .
- Press  or  to scroll to the correct hour and press  to navigate to the minutes.
- Press  or  to scroll to the correct minutes and press  to navigate to the AM or PM field. If you are using a 24-hour clock, the AM/PM field does not appear.
- Press  or  to scroll between AM and PM and press  when the correct setting appears. Select **Save**.

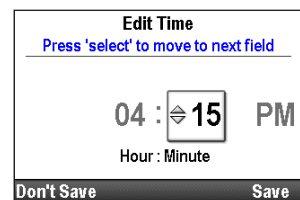
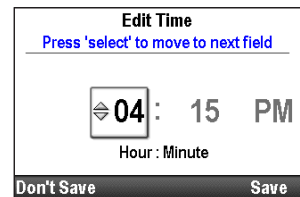
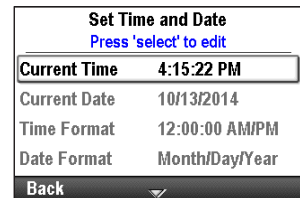

Current Date

To set the current date:

- In the Set Time and Date menu, press **▲** or **▼** to highlight **Current Date** and press **select**.
- Press **▲** or **▼** to scroll to the correct month and press **select** to navigate to the day.
Note: This example is for the Month/Day/Year date format. The date format is indicated below the date so that you know which field is changing.
- Press **▲** or **▼** to scroll to the correct day and press **select** to navigate to the year.
- Press **▲** or **▼** to scroll to the correct year and select **Save**.

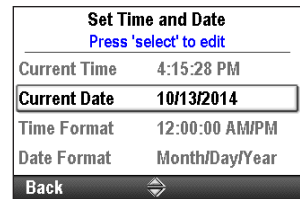

Time Format

The time format setting allows you to select either a 12-hour or 24-hour clock format, and to set the character used for indicating the hours, minutes and seconds separators. The formats available are as follows:

- 12:00:00 AM/PM
- 12.00.00 AM/PM
- 24:00:00
- 24.00.00

To set the time format:

- In the Set Time and Date menu, press **▲** or **▼** to highlight **Time Format** and press **select**.
- Unlock the keypad.
- Press **▲** or **▼** to highlight the desired time format and select **Save**.

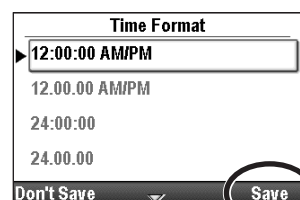
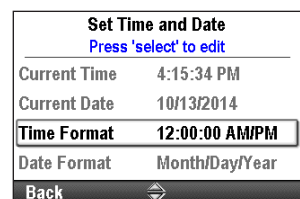



Date Format



The date format option allows you to select 1 of 3 formats for indicating the day, month, and year. The formats available are as follows:

- Month/Day/Year
- Day/Month/Year
- Year/Month/Day

To set the date format:

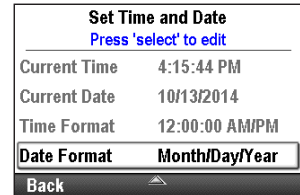
1. In the Set Time and Date menu, press  or  to highlight **Date Format** and press .



2. Unlock the keypad.
3. Press  or  to highlight the desired date format and select **Save**.

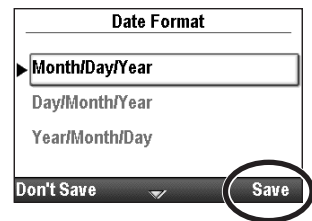

Daylight Saving Time

The pump time and date do not automatically update for daylight saving time. If you live in a geographical area that follows daylight saving time, you must manually update the time and date. You may choose to change the time while the pump is currently being used by a patient, or wait until the patient is finished with the infusion. However, because delivery of some therapies is affected by a time and/or date change, it is recommended that you wait until the infusion is complete.

Note: If you update the time while the pump is in use, the timestamps in the event and delivery logs are not updated to reflect daylight saving time prior to the change. All events record the reported time from when the event actually occurred. For your reference, the event log records the time when it was changed.

Reports

The reports screen is used to view a variety of reporting and record-keeping functions. The reports available are:

- Total Given (not available for PCA therapies)
- Given and PCA Dose Counters (PCA therapies only)
- PCA Dose Graph (PCA therapies only)
- Delivery History and Pie Chart
- Delivery Log
- Event Log
- Protocol Library Summary
- Device Information

The reports can be viewed at any time, with the pump running or stopped.

In the Tasks menu, press  or  to highlight **View Reports** and press .

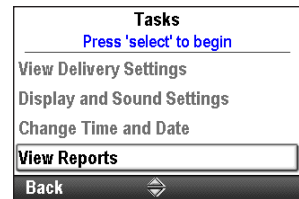

Total Given

Note: This report is not available for PCA therapies. See *Given and PCA Dose Counters* on page 99, and *PCA Dose Graph* on page 99 for reports specific to PCA therapies.

The total given report shows the amount of drug given since the date and time indicated, which is the last time the counter was cleared manually, or when a new protocol or new patient was started.

To clear the Given counter:

1. In the Reports menu, press  or  to highlight **Total Given** and press .

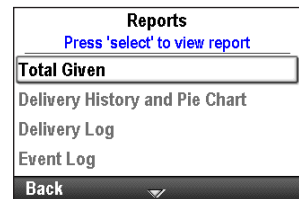

2. Select **Clear Given** to clear the counter. This also updates the time and date on this screen.

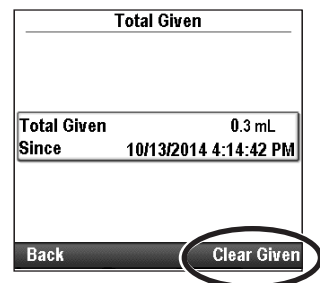



Given and PCA Dose Counters

Note: This report applies only to PCA therapies. See *Total Given* on page 98 for reports specific to therapies other than PCA.

This report shows the total amount of drug given and the number of PCA doses given and attempted since the date and time indicated, which is the last time the information was cleared manually, or when a new protocol or new patient was started.

- **Total Given** shows the amount of drug (in programmed units) delivered by continuous rate, clinician boluses, and PCA doses.
- **PCA Doses Given** shows the number of PCA doses actually delivered to the patient, including any doses stopped in progress.
- **PCA Doses Attempted** shows the total number of PCA doses attempted by the patient while the pump was running, including those that were delivered, locked out, and stopped in progress.

To clear total given and/or the dose counters:

1. In the Reports menu, press  or  to highlight **Given and PCA Dose Counters** and press .

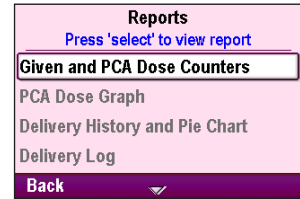

2. Press  or  until the counter you wish to clear is highlighted.

3. Select **Clear Given** or **Clear Doses** to clear the counter. This also updates the time and date on this screen.

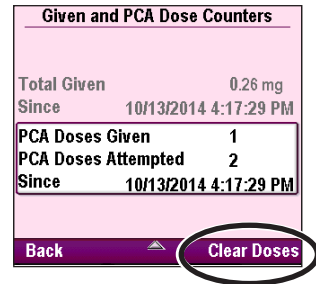
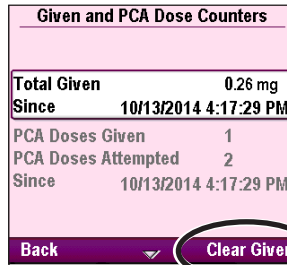



PCA Dose Graph

Note: This report applies only to PCA therapies. For all other therapies, information is available in the report *Delivery History and Pie Chart*.

This graph displays the number of doses attempted and given in 30 minute increments, starting from the current time to 8 hours in the past, or since the start of a new protocol or new patient. Select this report to review the number of attempted doses for a particular time frame.

To view the PCA Dose Graph:

In the Reports menu, press  or  to highlight **PCA Dose Graph** and press .

In this example, the patient has attempted 4 PCA doses, and 3 were delivered.

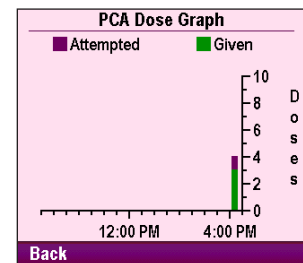
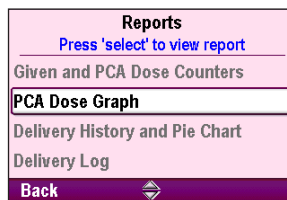

Delivery History and Pie Chart

The delivery history and pie chart is a graphical view of the total drug given over a specified time frame, or since the start of a new patient or new protocol. The delivery history is displayed in the units for the current protocol.

The time frame can be adjusted in various intervals from 30 minutes to 7 days. To view the pie chart in different time frames, press **▲** or **▼**. This provides a quick review of the methods of delivery over the interval selected.

The information displayed in the pie chart differs for each therapy, as shown in the table below:

PCA	Continuous	Intermittent	Step	Taper
KVO Rate	KVO Rate	KVO Rate	KVO Rate	KVO Rate
Continuous Rate	Continuous Rate	Doses	Step and Plateau	Taper and Plateau
PCA Dose				
Clinician Bolus				

To view the Delivery History and Pie Chart:

In the Reports menu, press **▲** or **▼** to highlight **Delivery History and Pie Chart** and press **select**.

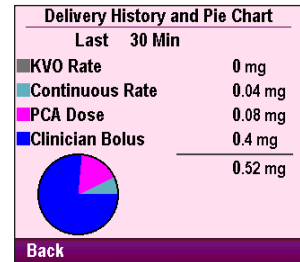
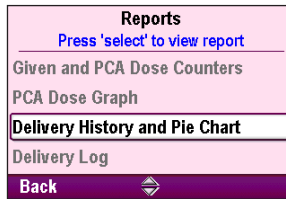

Delivery Log

The delivery log is a subset of the event log and contains specific information regarding delivery events. The delivery log is maintained by the pump, and displays all entries since the last time a new patient was started. Delivery log information includes but is not limited to:

- Programming changes to the patient-specific parameters
- Changes to infusion status
- Pump started, stopped, powered up, and powered down
- Starting a new protocol

To view the Delivery Log:

1. In the Reports menu, press **▲** or **▼** to highlight **Delivery Log** and press **select**.
2. While viewing the delivery log, you may quickly scroll from the oldest to the newest entries by selecting **Show Oldest** or **Show Newest**.

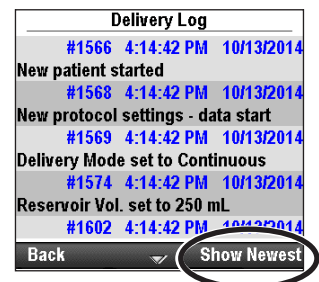
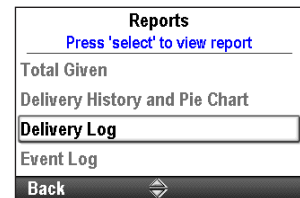

Event Log

The event log records the following types of events: hourly given totals, dose delivery, alarms, error codes, power source changes (including power losses), cassette changes, protocol library changes, and changes

to pump programming or settings. The pump records the time and date of each event, and lists events in order, with the most recent at the bottom of the screen through the last 5000 events. When the event log reaches 5000 events, and a new event occurs, the oldest event is replaced with the next oldest event in order of occurrence.

The event log can be viewed at any time, with the pump running or stopped. The event log is maintained by an internal back up battery during and after the pump is powered off or when the pump loses power unexpectedly due to removal or depletion of power source (AC adapter, AA alkaline batteries, or rechargeable battery pack).

To view the Event Log:

1. In the Reports menu, press **▲** or **▼** to highlight **Event Log** and press **select**.
2. While viewing the event log, you may quickly scroll from the oldest to the newest entries by selecting **Show Oldest** or **Show Newest**.

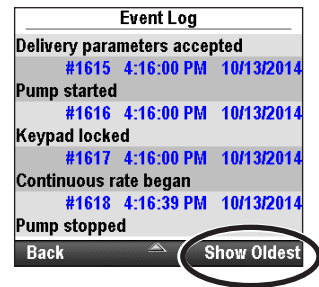
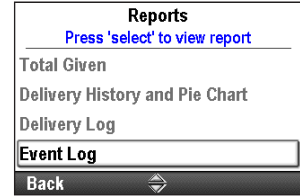

Protocol Library Summary

The protocol library summary allows you to view information about the protocol library currently installed in the pump. This screen tells you the name of the protocol library, the revision, and the number of protocols in the library. **To view the Protocol Library Summary:**

In the Reports menu, press **▲** or **▼** to highlight **Protocol Library Summary** and press **select**.

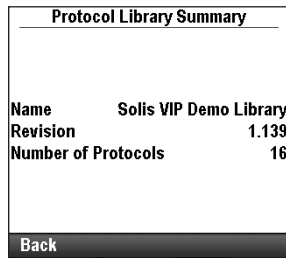
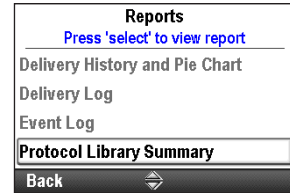

PharmGuard® Example

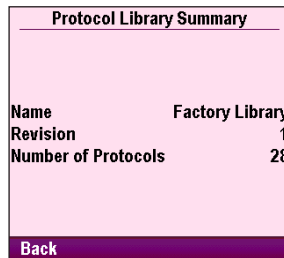

Select Example

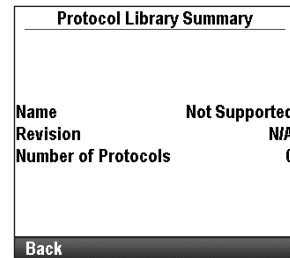

Standard Example

Device Information

The device information screen allows you to view the information about the pump, including:

- Serial number
- Software version
- User interface (UI) hardware revision
- Motor processor (MP) hardware and software revision
- Language revision
- Last error code (if one exists)

Note: Follow your facility’s procedure for handling error codes. See *Alarms and Messages* on page 113 for more information.

To view the Device Information:

In the Reports menu, press  or  to highlight **Device Information** and press .

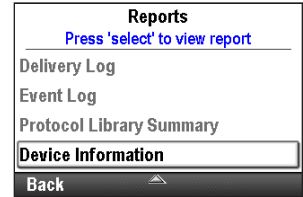

PharmGuard® Example



Select Example



Standard Example

Advanced Tasks Menu Overview

Most pump configurations are set up by a CADD®-Solis system administrator. Protocol libraries consisting of therapies, qualifiers, and drugs are created using the PharmGuard® Administrator Medication Safety Software. The Advanced Tasks menu allows you to select a standard therapy protocol created by the CADD®-Solis administrator, or make changes to an individual protocol for single use, or to manually program a protocol.

Note:

- When creating or editing a protocol under Advanced Tasks, it is important to note that the edits made affect only the protocol currently in use.
- The Advanced Tasks screens revert to the home screen if there is a 4 minute delay between button presses. Make certain you are still in the Advanced Tasks menu after any delays.
- Most of the advanced tasks require a security code to unlock the keypad. This step is necessary only if the keypad is not already unlocked.

WARNING:

- Do not disclose the pump security codes or any other information that would allow the patient or unauthorized clinician complete access to programming and operating functions. Improper programming could result in serious patient injury or death.
- Do not leave the pump unattended while unlocked. All programming functions are accessible while the pump is unlocked, and improper programming could result in serious patient injury or death.

The following functions are on the Advanced Tasks menu.

Advanced Task Menu Function	Description on Page
Give Clinician Bolus (PCA therapy)	45
Step Up (Step therapy)	69
Step Down (Step therapy)	70
Patient Permissions	103
Air and Occlusion Settings	105
Alarm Settings	108
Security Settings	20
Start New Patient	29
Start New Protocol Same Patient	29
Delivery Hard and Soft Limits	35
Reset to Factory Settings	112

To access the Advanced Tasks menu:

1. From the home screen, select **Tasks**.
2. Press **▲** or **▼** to highlight **View Advanced Tasks** and press **select**.

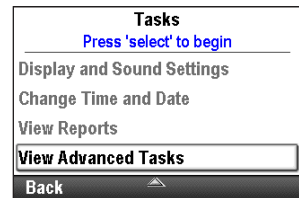

Patient Permissions

Security levels are used to limit unauthorized access to certain programming and operating functions. In some cases, the default security settings may be changed to allow patients additional access to pump functions. Do not reduce security settings without providing proper training to patients.

The Patient Permissions task allows you to control a patient’s access to two specific tasks: priming and setting a delayed start. Setting the permission to Off allows the patient to access one or both tasks without having to enter a security code. Setting the permission to On restricts the patient’s access to one or both tasks because a security code is required.

WARNING:

- Do not disclose the pump security codes or any other information that would allow the patient or unauthorized clinician complete access to programming and operating functions. Improper programming could result in serious patient injury or death.
- Do not leave the pump unattended while unlocked. All programming functions are accessible while the pump is unlocked, and improper programming could result in serious patient injury or death.



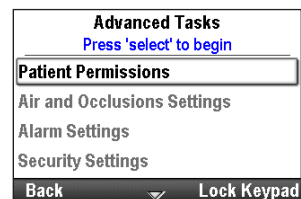

In the Advanced Tasks menu, press **▲** or **▼** to highlight **Patient Permissions** and press **select**.



Priming Security On/Off

Setting this value to Off allows patients to prime the tubing without having to enter a security code.

To set patient permissions for priming activity:



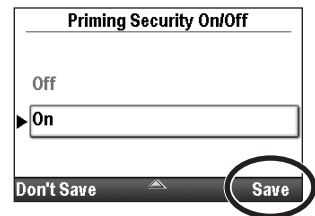
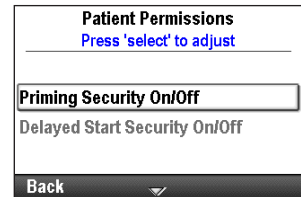

1. Stop the pump if it is running.
2. In the Patient Permissions menu, press  or  to highlight **Priming Security On/Off** and press .
3. Unlock the keypad.
4. Press  or  to set the security to **On** (security code required) or **Off** (no security code required) and select **Save**.



Delayed Start Security On/Off

Setting this value to Off allows patients to set delayed starts (and change next dose start times for Intermittent therapies) without having to enter a security code.

To set patient permissions for delayed start security:

1. Make certain the pump is stopped.
2. In the Patient Permissions menu, press  or  to highlight **Delayed Start Security On/Off** and press .
3. Unlock the keypad.
4. Press  or  to highlight **On** (security code required) or **Off** (no security code required), and select **Save**.

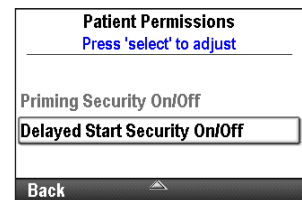

Air and Occlusion Settings

In the Advanced Tasks menu, press **▲** or **▼** to highlight **Air and Occlusions Settings** and press **select**.

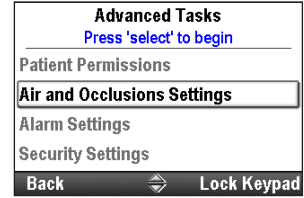

Air Detector On/Off

The pump is built with an integrated air detector. The pump may be customized to use the air detector. If air is detected in the part of the tubing that passes through the air detector, an alarm sounds and delivery stops. If an air detector is not required, it may be turned off.

The Air Detector On/Off setting allows you to control whether the air detector is turned on or off. If the air detector is turned on, an alarm sounds when air is detected in the fluid path. For certain therapies, for example, subcutaneous infusions, it may be desirable to turn the air detector off.

WARNING:

- If the air detector is turned off, the pump does not detect air in the fluid path. It is recommended that you periodically inspect the fluid path and remove any air to prevent air embolism, which could result in serious patient injury or death.
- The air detector, when turned on, may be set to detect and alarm for air bubbles as small as 150 uL. The High Sensitivity setting and/or filtered sets should be considered for patients and therapies with a risk of harm due to an air embolism.

To turn the air detector on or off:

1. Make certain the pump is stopped.
2. In the Air and Occlusion Settings menu, press **▲** or **▼** to highlight **Air Detector On/Off** and press **select**.
3. Unlock the keypad.
4. Press **▲** or **▼** to highlight **On** or **Off**, and select **Save**.

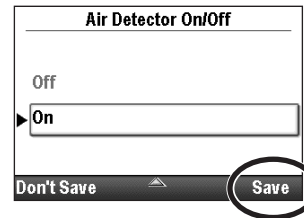
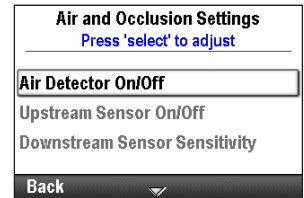



Air Detector Sensitivity

Note: If the air detector is set to “Off”, this feature does not appear in the menu.

If the air detector is set to “On”, the air detector sensitivity option allows you to customize how sensitive the pump should be to any air bubbles in the tubing. You may program the pump to have a high or low sensitivity.

To set the air detector sensitivity:

1. Make certain the pump is stopped.
2. In the Air and Occlusion Settings menu, press  or  to highlight **Air Detector Sensitivity** and press .

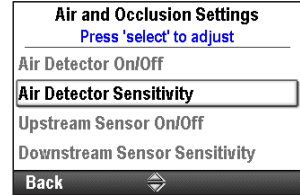

3. Unlock the keypad.
4. Press  or  to highlight **Low** or **High**, and select **Save**.

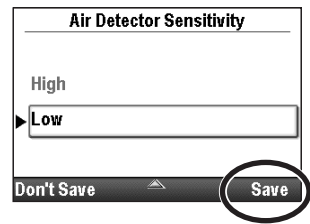



Upstream Sensor On/Off

An upstream occlusion is a blockage in the tubing between the pump and the fluid container. The pump contains a sensor that determines if there is an upstream occlusion. This feature can be set to On or Off. If this sensor is set to On and an upstream occlusion is detected, an alarm sounds, delivery stops, and the display shows that there is an upstream occlusion. An upstream occlusion is detected only when administration sets and bags are being used.

Note: The pump does not test for an upstream occlusion when using a medication cassette reservoir, even if the upstream occlusion sensor is set to “On.”

WARNING: When the upstream occlusion sensor is turned off, the pump does not detect occlusions upstream between the pump and the reservoir. Periodic inspection of the fluid path for kinks, a closed clamp, or other upstream obstructions is recommended. Upstream occlusions may result in nondelivery of medication. If undetected, occlusions could lead to serious patient injury or death.

To turn the upstream sensor on or off:

1. Make certain the pump is stopped.
2. In the Air and Occlusion Settings menu, press  or  to highlight **Upstream Sensor On/Off** and press .

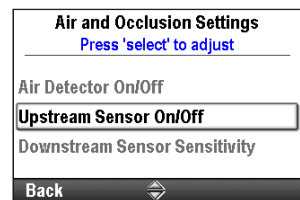

3. Unlock the keypad.
4. Press  or  to highlight **On** or **Off**, and select **Save**.

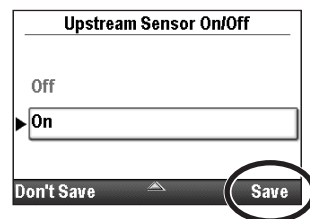





Downstream Sensor Sensitivity

A downstream occlusion is a blockage in the tubing between the pump and the patient. The pump contains a sensor that determines if there is a downstream occlusion. The downstream sensor sensitivity setting allows you to specify a high or low degree of response to pressure buildup in the downstream tubing. When a downstream occlusion is detected, an alarm sounds, delivery stops, and the display shows “High Pressure.”

Note: The downstream sensor is always On.

To set the downstream sensor sensitivity:

1. Make certain the pump is stopped.
2. In the Air and Occlusion Settings menu, press  or  to highlight **Downstream Sensor Sensitivity** and press .
3. Unlock the keypad.
4. Press  or  to highlight **Low** or **High**, and select **Save**.

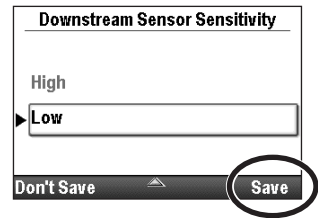
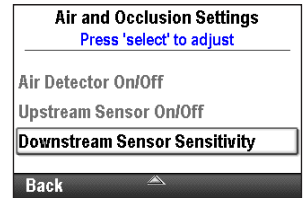

Alarm Settings

You may adjust various alarm settings through the Alarm Settings task in the Advanced Tasks menu. Some of the adjustable settings include whether or not an alarm is active, the type of alarm that sounds, and at what point the alarm sounds. See *Alarms and Messages* on page 113 for more information.

There are 4 types of alarms:

- High Priority
- Medium Priority
- Low Priority
- Informational

In the Advanced Tasks menu, press or to highlight **Alarm Settings** and press .

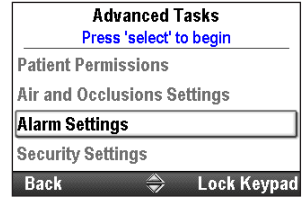

Infusion Alerts On/Off

This alarm setting is available for Step delivery mode only. Turning this setting On results in infusion notification screens 5 minutes before each automatic step up occurs.

To set the infusion alerts:

1. Make certain the pump is stopped.
2. In the Alarm Settings menu, press or to highlight **Infusion Alerts On/Off** and press .
3. Unlock the keypad.
4. Press or to highlight **Off** or **On** and select **Save**.

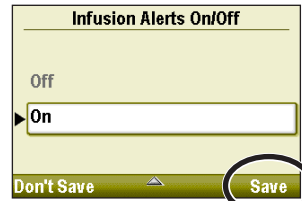
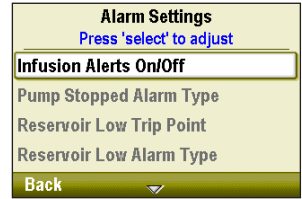

Pump Stopped Alarm Type

The pump stopped alarm allows you to select either a high priority or informational alarm as a reminder that the pump is stopped.

To set the pump stopped alarm type:

1. Make certain the pump is stopped.
2. In the Alarm Settings menu, press or to highlight **Pump Stopped Alarm Type** and press .
3. Unlock the keypad.
4. Press or to highlight **Informational** or **High Priority**, and select **Save**.

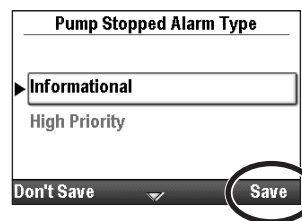
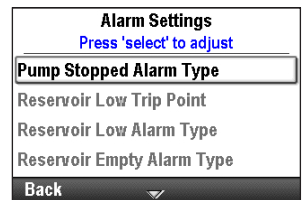



Reservoir Low Trip Point

The reservoir low trip point allows you to program the pump to alarm when the reservoir volume reaches a specified level. It can be programmed from 0 to 999 mL in 1 mL increments. If you prefer not to sound an alarm until the reservoir is empty, program the trip point to zero.



Note: When programming the reservoir volume trip point, keep the programmed delivery rate of the pump in mind so that sufficient time is available to gather replacement supplies before the reservoir becomes empty.

Once activated, a medium or low priority alarm sounds, depending on the type of alarm selected in the reservoir low alarm type.

To set the reservoir low trip point:

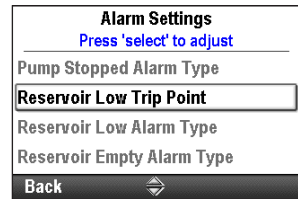
1. Make certain the pump is stopped.
2. In the Alarm Settings menu, press  or  to highlight **Reservoir Low Trip Point** and press .



3. Unlock the keypad.
4. Press  or  to set the trip point to the desired volume and select **Save**.

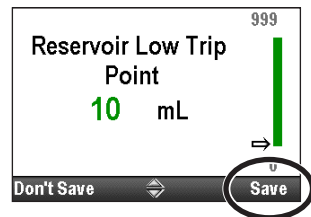

Reservoir Low Alarm Type

The reservoir low alarm type allows you to select either an “Insistent and One Time Only” alarm (medium priority) or a “Non-Insistent and Repeating” alarm (low priority) to inform the user that the reservoir volume is low.



Insistent and One Time Only: Alarm does not reoccur once it has been acknowledged with a push of the button on the pump.

Non-Insistent and Repeating: Alarm repeats at the 75%, 50%, and 25% marks of the amount determined in the reservoir low trip point.

To set the reservoir low alarm type:

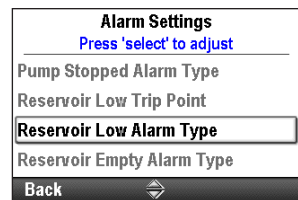
1. Make certain the pump is stopped.
2. In the Alarm Settings menu, press  or  to highlight **Reservoir Low Alarm Type** and press .



3. Unlock the keypad.
4. Press  or  to highlight **Insistent and One Time Only** or **Non-Insistent and Repeating**, and select **Save**.

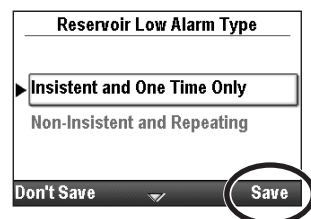





Reservoir Empty Alarm Type

The reservoir empty alarm type option allows you to select between two types of alarms when the reservoir is empty:

One Time Only: When a reservoir empty alarm occurs, you must press a button to acknowledge or silence the alarm. This alarm does not reoccur once it has been acknowledged.

Repeat Until Removed or Reset: When a reservoir empty alarm occurs, you must press a button to acknowledge or silence the alarm. The alarm is repeated every 5 minutes until the reservoir volume has been set to a new value, the reservoir is removed, or the pump is powered down.

To set the reservoir empty alarm type:



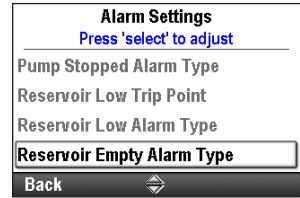





1. Make certain the pump is stopped.
2. In the Alarm Settings menu, press  or  to highlight **Reservoir Empty Alarm Type** and press .
3. Unlock the keypad.
4. Press  or  to highlight **One Time Only** or **Repeat Until Removed or Reset**, and select **Save**.



PM Reminder On/Off

If your facility establishes a maintenance program for the pump, you can use the PM reminder on/off option to program the pump to sound an alarm when it is time for preventive maintenance. The message begins appearing on the date programmed and during every power up until the date is reset. Use the PM reminder on/off screen to turn the alarm on and then continue to the PM reminder screen to specify the interval at which the message should appear, or use it to reset the reminder.

To turn the PM reminder on or off:

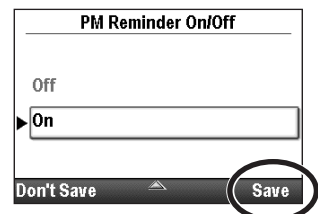
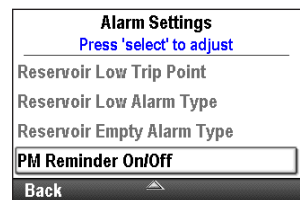

1. Make certain the pump is stopped.
2. In the Alarm Settings menu, press  or  to highlight **PM Reminder On/Off** and press .
3. Unlock the keypad.
4. Press  or  to highlight **Off** or **On**, and select **Save**.
5. If you set the **PM Reminder On/Off** to On, press  or  to highlight **PM Reminder** and press . Instructions for scheduling the PM Reminder are in the next section.



PM Reminder

The PM Reminder appears as an option only if the PM Reminder On/Off setting is set to “On”. Use the PM Reminder to schedule the amount of time that should pass before a preventive maintenance reminder displays (1 to 24 months).

To schedule the PM interval immediately after turning the PM Reminder On/Off setting to On:

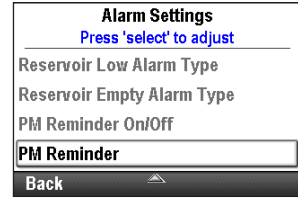

1. In the Alarm Settings menu, press  or  to highlight **PM Reminder** and press .







2. **PM Interval** is highlighted (see step 4 below to edit the settings).

PM Interval

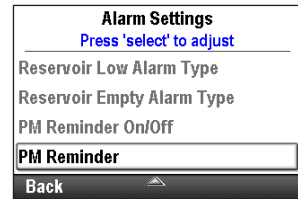
To edit the PM interval:

1. Make certain the pump is stopped.
2. In the Alarm Settings menu, press  or  to highlight **PM Reminder** and press .



3. Unlock the keypad, if necessary.
4. **PM Interval** is highlighted. Press  to edit it. Press  or  to choose the number of months that should pass before the next preventive maintenance reminder. The **Next Reminder** date displayed changes along with the PM Interval to reflect the actual date of the next reminder. Select **Save**.





Reset to Factory Settings

Reset to Factory Settings allows you to erase any custom PharmGuard® Administrator Medication Safety Software protocol library and pump settings, and restore the pump to the factory default settings.

Note: When the pump is reset to factory settings, all protocol library information is lost.

To reset the pump to factory settings:

1. Make sure the pump is stopped.
2. In the Advanced Tasks menu, press  or  to highlight **Reset to Factory Settings** and press .

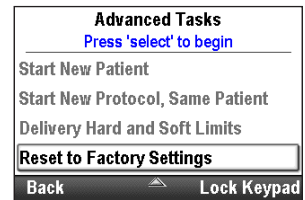

3. Unlock the keypad.
4. A screen appears that explains that you are about to erase the protocol library and pump settings. Select **Yes**.

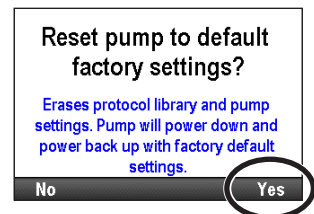

5. The pump powers down and restarts in the continuous mode without a protocol library, and in the default factory settings.

References and Troubleshooting

Alarms and Messages

The pump can sound multiple alarms. For many of the alarms, you have the option to “acknowledge” or “silence.”

- **Acknowledge**—the alarm clears from the screen.
- **Silence**—the alarm stays on the screen, but is silenced for 2 minutes before it sounds again. The alarm continues until it is acknowledged or resolved.

The alarms may have different sounds depending on the sound theme selected. There are 3 different sound themes for the alarms and beeps that the pump makes: standard, intense, and distinctive. See *Sound Theme* on page 93 for more information on previewing and selecting the sound themes.

Types of Alarms

System Fault Alarm

If this screen appears, an unrecoverable error may have occurred, such as a hardware or software fault. The amber indicator light is continuously illuminated during these conditions and is accompanied by an audible two-tone alarm. If a system fault occurs, the fault should be reported to Smiths Medical Customer Service or Smiths Medical International Ltd.

To clear this alarm, remove power from the pump by opening the battery door, and if necessary, removing the AC power. Close the battery door and turn the pump back on. If the error code does not repeat, Customer Service may suggest continued use of the pump. If the error is persistent, the pump must be returned for service.

Note: Document the error numbers displayed on the system fault screen to help Customer Service identify the problem.



System fault alarm (red).

The numbers relate to the error that caused the system fault.

CAUTION: If the power up results in an error message indicating that the protocol library was lost, do not proceed with using the pump. Follow your facility’s procedures for downloading protocol libraries

High Priority Alarm

A high priority alarm always pauses or stops the pump if it is running. The alarm is accompanied by a **red** screen, and it persists until acknowledged by the press of a key on the pump or until the condition that triggered the alarm goes away (for example, high pressure). The alarm can be silenced with a key press and will sound again after 2 minutes if the alarm condition still exists.



High priority alarm (red)

Medium Priority Alarm

A medium priority alarm does not stop the pump if it is running. The alarm is accompanied by an **amber** screen, and it persists until acknowledged by the press of a key on the pump or until the condition that triggered the alarm goes away. The alarm can be silenced with a key press and will sound again after 2 minutes if the alarm condition still exists.

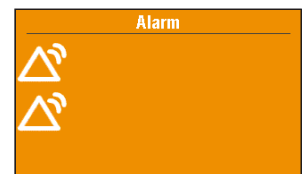

Medium priority alarm (amber)

Low Priority Alarm

A low priority alarm does not stop the pump if it is running. The alarm is accompanied by a **blue** screen, and it persists for 5 seconds unless it is acknowledged by the press of a key or the condition that triggered the alarm goes away before the 5 seconds have passed. (Some low priority alarms persist for longer than 5 seconds.)

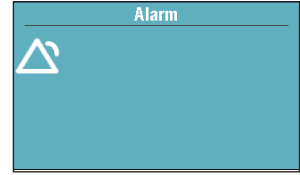

Low priority alarm (blue)

Multiple Alarms

The alarm system will maintain and manage multiple alarm conditions at the same time, but will only generate alarm signals from a single alarm at any time. When an alarm of higher priority is activated, its alarm signals will supersede those of any currently active lower priority alarm. When an alarm of equal or lower priority is activated, its alarm signals will follow at the removal of any currently active higher or of equal priority alarm. In this way, the operator awareness of lower or of equal priority alarms may be delayed until existing higher priority alarms are addressed by the operator.

Informational Message and Signals

An informational priority message does not stop the pump if it is running. This message appears in the status bar, and does not display a new alarm screen. It persists for 5 seconds and may be silent, requiring no acknowledgement. Some informational examples are “Cassette Locked,” and “Cassette Unlocked.”

When an alarm condition is active, in addition to the visual indication, the pump will sound an audible alarm that is distinguishable from other pump sounds. All audible alarms, no matter the sound theme used, will be distinguishable from other information signals that the device may sound.

The audible informational signals are not impacted by the sound theme settings. Audible informational signals include: key beeps, PCA dose granted beeps, stop mode beeps, informational message beeps, low battery beeps, and power on beeps. The audible characteristics of these informational signals may also be previewed along with the sound themes (see Administrator Settings Guide).

Alarm Algorithms

Most alarm algorithms are based on simple, singular, and unchangeable alarm limits; for example, Reservoir Volume Empty, Remote Dose Cord Disconnected, Delivery Cannot Be Started, Battery Removed, and Disposable Detached.

Alarm algorithms based on user configurable alarm limits are: High/Standard Flow Disposable Not Allowed, Delivery Limit, Reservoir Volume Low, Downstream Occlusion, Upstream Occlusion, Air In-Line, and Stop Mode Reminder.

Other alarm algorithm details included in the table of alarm messages.

Alarm Help Screens

Additional information may be displayed when certain alarms occur. The help screens describe what you can do to try to solve the current problem that is causing the alarm.

1. When an alarm occurs, select **Silence** to quiet the alarm.



- If help screens are available for the alarm, “Help” appears above the right soft key. To view the help screens, select **Help**.
- Follow the applicable instructions provided on the help screen. To page through all available help screens, press **Next** repeatedly. Press **Acknowledge** at any time to exit Help.
- “Retry Help” appears when no additional help steps are available. To page through the help screens again, press **Retry Help**. The Alarm screen reappears as in Step 2 above. Repeat Steps 2 and 3. When the alarm clears, the help screens will no longer be displayed.

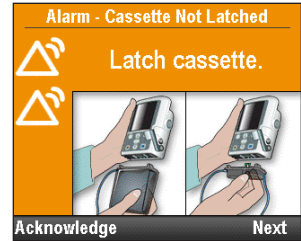

User Position

The user must position themselves to ensure alarm visibility and audibility with respect to distance from the device in the expected ambient light and noise conditions.

Note: Perform an alarm risk assessment to determine compatibility with facility alarm policies and care area requirements. If choosing an alternative alarm style, perform a risk assessment to ensure the operator’s recognition of the audible alarm.

Note: There is no power interruption limit to the device’s ability to restore alarm settings and behavior. The pump will retain alarm state upon power interruption if the alarm condition persists through the power interruption, and alarm algorithms are unaffected by power interruption.

Troubleshooting

Issue	Possible Solution
A continuous two-tone alarm is sounding, and the amber light is lit or flashing.	Delivery has stopped. Read the message on the display and refer to the list of messages in the table below. If the display is blank or contains random characters, the 4 AA batteries or the rechargeable battery pack may be depleted. Install 4 new AA batteries or a rechargeable battery pack.
The pump is sounding 2 beeps every 2 seconds, and the amber light is flashing.	Look at the message on the display and refer to the list of messages in the table below.
Three beeps sound every 5 minutes.	This is a reminder that the pump is stopped.
After installing 4 new AA batteries and powering up the pump, no screen appears and no beep sounds.	The batteries may be installed incorrectly. Review the procedure for installing batteries. Be sure to match the polarity (+ and -) markings inside the battery door with the markings on the batteries. If there is still no power, the batteries may be completely depleted. Install 4 new AA batteries.

Alarms and Messages, Alphabetical List

Alarm / Message	Alarm Priority	Description / Corrective Action
(Screen is blank and alarm is sounding)	High	The pump was delivering and the batteries were removed or the battery door was opened. The pump lost power and is no longer delivering. Clear the alarm by turning the pump back on, or the alarm will stop after the power has been off for a minimum of 2 minutes.
A setting was edited, but not saved, and the edit was lost.	Medium	A parameter was being manually edited, but it was not saved and the pump reverted to the home screen. Select Acknowledge to clear the alarm and if appropriate, edit the parameter and save.
AC adapter disconnected.	Low	The AC adapter was disconnected and the pump is being powered by the 4 AA batteries or the rechargeable battery pack. Select Acknowledge to clear the alarm, or the alarm will automatically clear after 5 seconds. If desired, reconnect the AC adapter.
Air in-line detected. Press 'Acknowledge' then prime tubing.	High	The air detector has detected air in the fluid path. The fluid path may contain air bubbles. The pump was delivering and is now stopped and will not run. Select Acknowledge to clear the alarm. If the fluid path contains air bubbles, close the clamps and disconnect the fluid path from the patient. Follow the instructions for removing air by priming (see page 86 for more information on priming). Restart the pump.
Battery depleted. Pump stopped.	High	The pump was delivering but is now stopped and the battery power is too low to operate the pump. If the AC adapter is attached, select Acknowledge to clear the alarm. Remove the batteries. Install 4 new AA batteries or a rechargeable battery pack. To start delivery, good batteries must always be installed even when an external source of power is connected. If appropriate, restart the pump.
Battery depleted. Pump will not run.	Medium	The battery power is too low to operate the pump. If the AC adapter is attached, select Acknowledge to clear the alarm. Remove the batteries. Install 4 new AA batteries or a rechargeable battery pack. To start delivery, good batteries must always be installed even when an external source of power is connected. If appropriate, restart the pump.
Battery low. Replace battery.	Low	The rechargeable battery pack or the 4 AA batteries are low but the pump is still operable. Select Acknowledge to clear the alarm, or the alarm will automatically clear after 5 seconds. Recharge or change the rechargeable battery pack or replace the 4 AA batteries soon.

Alarm / Message	Alarm Priority	Description / Corrective Action
Battery removed. Pump stopped.	High	The rechargeable battery pack or the 4 AA batteries were removed while the pump was running. The pump was delivering and is now stopped. Select Acknowledge to clear the alarm. Install 4 new AA batteries or a rechargeable battery pack. To start delivery, good batteries must always be installed even when an external source of power is connected. If appropriate, restart the pump.
Battery removed. Pump will not run.	Medium	The pump is stopped and the rechargeable battery pack or the 4 AA batteries were removed, but the pump is still powered by the AC adapter. Select Acknowledge to clear the alarm. Install a fully charged rechargeable battery pack or 4 new AA batteries. To start delivery, good batteries must always be installed, even when an external source of power is connected.
Cannot start pump. Rechargeable battery has reached end of use.	Medium	The rechargeable battery pack is at the end of its life. It has been discharged and recharged so many times that it is no longer able to hold a good charge. Remove the battery from service. To start delivery, good batteries must always be installed even when an external source of power is connected. Select Acknowledge to clear the alarm. Install 4 new AA batteries or a new rechargeable battery pack. If appropriate, start the pump.
Cannot start pump with a depleted battery.	Medium	The battery power is too low to operate the pump. To start delivery, good batteries must always be installed even when an external source of power is connected. Select Acknowledge to clear the alarm. Install 4 new AA batteries or a fully charged rechargeable battery pack. If appropriate, start the pump.
Cannot start pump with a reservoir volume of zero.	Medium	The reservoir volume in the pump is set to zero. Select Acknowledge to clear the alarm. Edit or reset the reservoir volume to the correct value. If appropriate, start the pump. See page 29 for more information about resetting the reservoir volume.
Cannot start pump with air in-line. Prime tubing.	Medium	The air detector has detected air in the fluid path directly under the air detector. The fluid path may contain air bubbles. Select Acknowledge to clear the alarm, then: If the fluid path contains air bubbles, close the clamps and disconnect the fluid path from the patient. Follow the instructions for removing air by priming (see page 86 for more information). If appropriate, start the pump.
Cannot start pump with an unusable battery.	Medium	The batteries installed are either the wrong kind of AA batteries, or the rechargeable battery pack is not compatible with the pump. Select Acknowledge to clear the alarm. Remove the batteries. Install 4 new AA batteries or a rechargeable battery pack. To start delivery, good batteries must always be installed even when an external source of power is connected. If appropriate, start the pump.
Cannot start pump without a battery.	Medium	The pump does not have any batteries installed, although it is still powered by the AC adapter. Select Acknowledge to clear the alarm. Install 4 new AA batteries. To start delivery, good batteries must always be installed even when an external source of power is connected. If appropriate, start the pump.
Cannot start pump without a latched and locked cassette.	Medium	The pump will not start without a cassette attached and locked. Select Acknowledge to clear the alarm. Make sure a cassette is properly attached and locked, then start the pump. Note: This alarm has associated help screens.
Cannot start pump without a latched cassette.	Medium	The pump will not start without a cassette attached. Select Acknowledge to clear the alarm. Make sure a cassette is properly attached, then start the pump. Note: This alarm has associated help screens.

Alarm / Message	Alarm Priority	Description / Corrective Action
Cassette detached. Pump stopped.	High	The cassette was detached while the pump was delivering and the pump is now stopped. Select Acknowledge to clear the alarm. Reattach the cassette and if appropriate, restart the pump.
Cassette locked, but not latched. Unlock and reattach cassette.	High	The cassette/keypad lock is locked, but there is no cassette attached. The pump is stopped and will not run. Select Acknowledge to clear the alarm. Unlock the cassette/keypad lock and reattach the cassette.
Cassette not attached properly. Reattach cassette.	High	The cassette is not properly attached. Close the tubing, remove the cassette, then reattach. If the alarm persists, replace the cassette. Note: You must remove the cassette to continue.
Cassette unlocked. Lock cassette.	Medium	This is a reminder that the cassette is not locked while the pump is delivering. Lock the cassette to clear the alarm.
Cassette was partially unlatched. Fully remove and reattach the cassette.	Medium	The cassette was not completely removed from the pump before it was reattached and the pump's sensors are not able to detect the cassette type. Remove the cassette and reattach it, then verify the cassette type in the pump display. If the alarm persists, replace the cassette. Note: You must remove the cassette to continue.
Check for empty tubing or reservoir. Pump stopped.	High	The tubing beneath the pump may not contain fluid, or the fluid container may be empty. The pump is stopped and will not run. Select Acknowledge to clear the alarm. Check to see if the fluid container is empty. If fluid is present in the reservoir, clamp the tubing, remove the cassette, and check for air in the tubing. If the alarm persists, remove the pump from service and contact Customer Service to return the pump for service.
Delayed start time adjusted to [date] [time].	Medium	A delayed start is programmed and a change to the time or date caused an adjustment to the start time in order to keep the interval unchanged from the current time and date.
Delivery limit reached. Partial PCA dose delivered. Running at KVO rate.	Low	The programmed delivery limit has been reached, a portion of the PCA dose was delivered, and the pump is delivering fluid at the KVO rate. This alarm occurs when the continuous rate is programmed to greater than 0 mL/hr, and either a PCA dose or the continuous rate has caused the delivery limit to be exceeded. Select Acknowledge to clear the alarm or the alarm will automatically clear after 5 seconds.
Delivery limit reached. Running at KVO rate.	Low	The programmed delivery limit has been reached, and the pump is delivering fluid at the KVO rate. This alarm occurs when the continuous rate is programmed to greater than 0 mL/hr, and either a PCA dose or the continuous rate has caused the delivery limit to be exceeded. Select Acknowledge to clear the alarm or the alarm will automatically clear after 5 seconds.
Delivery too slow.	Medium	The pump is busy with too many activities and does not have sufficient resources to support the programmed delivery rate. Delivery has fallen behind. Select Acknowledge to clear the alarm. If this alarm occurs regularly, remove the pump from use and contact Customer Service to return the pump for service.
Depleted battery is charging.	Low	The rechargeable battery pack is depleted and is being recharged with the AC adapter. Select Acknowledge to clear the alarm or the alarm will automatically clear after 5 seconds.
Dose is now overdue. Pump is stopped.	Medium	The pump is stopped and a dose is overdue for its scheduled delivery. Select Acknowledge to clear the alarm, and then start the pump.
Dose scheduled to start in [time]. Pump is stopped.	Low	The pump is stopped and a dose is scheduled for delivery in the time indicated. Select Acknowledge to clear the alarm, and then start the pump.

Alarm / Message	Alarm Priority	Description / Corrective Action
Downstream occlusion. Clear occlusion between pump and patient.	High	<p>The pump detects high pressure, which may be resulting from a downstream blockage, a kink in the fluid path, or a closed tubing clamp. Delivery is paused and will resume if the occlusion is removed.</p> <ul style="list-style-type: none"> Remove the obstruction to resume operation. Or select Stop Pump to stop the pump and silence the alarm for 2 minutes, then remove the obstruction and restart the pump. <p>Note: To reduce the potential for a bolus delivery after an occlusion, perform the following:</p> <ol style="list-style-type: none"> Press stop/start  to stop the pump. Close the distal clamp. If the distal clamp is the cause of obstruction, keep it closed and continue with step 4. Remove the obstruction. Detach the CADD™ medication cassette reservoir or CADD® administration set from the pump. Open the Flow Stop feature, if present. Wait 10 seconds. Close the Flow Stop feature, if present. Reattach the CADD™ medication cassette reservoir or CADD® administration set to the pump. Open the distal clamp. Review the pump program. Restart the pump. <p>Note: This alarm has associated help screens.</p>
External power source faulty. Change power source.	Medium	<p>The AC adapter output voltage is too high. Select Acknowledge to clear the alarm. The AC adapter is faulty, remove from service.</p>
High flow admin set required. Remove cassette.	High	<p>The delivery-specific parameters are programmed to values that cause the maximum rate of delivery to exceed 250 mL/hr, which requires a high flow administration set.</p> <p>Replace the standard volume cassette with a high volume administration set to continue.</p> <p>Note: Do not manually adjust the delivery rate to override pump programming without written authorization from the prescribing physician.</p>
High volume admin set not allowed. Remove cassette.	High	<p>The CADD® high volume administration set cannot be used. The pump is stopped and will not run.</p> <p>Replace the high volume administration set with a standard volume cassette to continue.</p> <p>Note: Do not manually adjust the delivery rate to override pump programming without written authorization from the prescribing physician.</p>
Infusion is now overdue. Pump is stopped.	Medium	<p>The pump is stopped and the infusion is overdue for its scheduled delivery. Select Acknowledge to clear the alarm, and then start the pump.</p>
Infusion scheduled to start in [time]. Pump is stopped.	Low	<p>The pump is stopped and an infusion is scheduled for delivery in the time indicated. Select Acknowledge to clear the alarm, and then start the pump.</p>
Key stuck. Release key or remove power. Pump stopped.	High	<p>A key may be pressed down. The pump is stopped and will not run. Make sure there is nothing pressing on any of the keys.</p> <p>If the alarm persists, close the tubing clamp, remove the batteries to turn off the pump, and remove the pump from use. Contact Customer Service to return the pump for service.</p>

Alarm / Message	Alarm Priority	Description / Corrective Action
Lock cassette to start pump.	Medium	PCA mode only. The cassette must be locked onto the pump before beginning delivery. Lock the cassette to clear the alarm and the pump will automatically start. Note: This alarm has associated help screens.
Loss of power occurred while running. Replace AA batteries.	Medium	The pump lost power while it was running. This alarm occurs when the pump restarts. The battery power is too low to operate the pump. If the AC adapter is attached, select Acknowledge to clear the alarm. Remove the batteries. Install 4 new AA batteries or a rechargeable battery pack. To start delivery, good batteries must always be installed even when an external source of power is connected. If appropriate, restart the pump.
Motor service due.	Medium	The pump motor requires service. Select Acknowledge to clear the alarm. Remove the pump from use at the next cassette change and contact Customer Service to return the pump for service.
New pump settings downloaded. Press 'Acknowledge' then review.	Low	A new protocol was just sent to the pump from the PharmGuard® Administrator Medication Safety Software. Select Acknowledge to clear the alarm. Review the protocol to ensure that it is correct.
Next dose start time adjusted to [date] [time].	Medium	A change to the time or date caused an adjustment to the next dose start time in order to keep the interval unchanged from the current date and time.
PCA dose cord button stuck. Release or remove cord.	High	The PCA remote dose cord button may be pressed down. The pump is stopped and will not run. Make sure nothing is pressing on the PCA remote dose cord button. If the alarm persists, remove the PCA remote dose cord to clear the alarm and contact Customer Service. Use the PCA dose  button on the pump, or use another PCA remote dose cord.
PCA dose cord disconnected.	Medium Low	Medium: The PCA remote dose cord was disconnected from the pump while the pump was delivering. Select Acknowledge to clear the alarm or reattach the PCA remote dose cord. Low: The PCA remote dose cord was disconnected from the pump while the pump was stopped. Select Acknowledge to clear the alarm or the alarm will automatically clear after 5 seconds.
Preventive maintenance due.	Medium	Your facility established a maintenance program for the pump and the pump is due for preventive maintenance. Select Acknowledge to clear the alarm and refer to your facility's policy for preventive maintenance.
Protocol library updating. Reselect protocol when update complete.	Medium	A new or updated protocol library is currently being sent to the pump. The pump will not allow the selection of any new protocols while this update is in process. Select Acknowledge to clear the alarm, or it will automatically clear when the update is complete.
Pump does not have a protocol library.	Medium	The PharmGuard® Software Enabled pump had a custom protocol library the last time it was powered on, but now it does not. This may happen if the pump was reverted to the factory default, recently had a software update, or if an attempt to install a custom PharmGuard® Software protocol library failed. Select Acknowledge to clear the alarm and contact the CADD®-Solis system administrator to download a new protocol library.
Pump settings and patient data lost.	Medium	The pump reverted to the factory default. The pump was either manually reverted to this default, recently had a software update, or has not been in use for some time. Select Acknowledge to clear the alarm and contact the CADD®-Solis system administrator to reprogram the pump.
Pump stopped by an alarm that has since cleared.	High	The pump was stopped by another high priority alarm. That alarm was not acknowledged, but the problem has since cleared. Select Acknowledge to clear the alarm and if appropriate, restart the pump. The Event Log recorded the alarm that stopped the pump. For information on accessing the Event Log, see page 100.

Alarm / Message	Alarm Priority	Description / Corrective Action
Pump stopped reminder. When ready, press the stop/start  key.	High	The pump was stopped and is not delivering. Select Acknowledge to clear the alarm. Start the pump, if appropriate. The alarm will repeat in 5 minutes if the pump is not restarted or powered down.
Rechargeable battery near end of use. Replace battery.	Medium	The rechargeable battery pack is near the end of its life. It has been discharged and recharged so many times that it will soon be at the end of its use. You may continue to use it in this state.
Rechargeable battery reached end of use. Pump will not run.	High	The rechargeable battery pack is at the end of its life. It has been discharged and recharged so many times that it is no longer able to hold a good charge. Remove the battery from service. Install 4 new AA batteries or a fully charged rechargeable battery pack. To start delivery, good batteries must always be installed even when an external source of power is connected. If appropriate, restart the pump.
Remove and reattach cassette.	High	The pump has detected a damaged cassette. Close the tubing clamp and inspect the cassette for damage. The pump is stopped and will not run. Replace cassette if necessary. Note: You must remove the cassette to continue. Note: This alarm also occurs if a cassette is attached during one of the following situations: <ul style="list-style-type: none"> • The pump is set to the factory default, and then powered off, and then on again. • The pump was loaded with new software, and then powered off, and then on again.
Reservoir volume is zero. Pump stopped.	High	The reservoir volume is 0.0 mL. The pump was delivering, but is now stopped and will not run. Select Acknowledge to clear the alarm. Attach a new reservoir, and reset or edit the value of the reservoir volume, if appropriate.
Reservoir volume low.	Medium Low	Medium: The programmed reservoir volume trip point has been reached, indicating the level of fluid in the reservoir is low. Select Acknowledge to clear the alarm. Low: The programmed reservoir volume trip point has been reached, indicating the level of fluid in the reservoir is low. Select Acknowledge to clear the alarm, or the alarm will automatically clear after 5 seconds. Prepare to install a new reservoir, and reset or edit the value of the reservoir volume, if appropriate.
Unknown cassette type. Remove cassette.	High	A cassette that is incompatible with the pump is detected. The pump is stopped and will not run. Close the tubing clamp, remove and then reattach the cassette. If the alarm persists, replace the cassette. Note: You must remove the cassette to continue.
Unusable battery. Pump stopped.	High	The batteries installed are either the wrong type of AA batteries, or the rechargeable battery pack is not compatible with the pump. Select Acknowledge to clear the alarm. Remove the battery or batteries from service. Install 4 new AA batteries or a fully charged rechargeable battery pack. To start delivery, good batteries must always be installed even when an external source of power is connected. If appropriate, start the pump
Unusable battery. Pump will not run.	Medium	The batteries installed are either the wrong type of AA batteries, or the rechargeable battery pack is not compatible with the pump. Select Acknowledge to clear the alarm. Remove the battery or batteries from service. Install 4 new AA batteries or a fully charged rechargeable battery pack. To start delivery, good batteries must always be installed even when an external source of power is connected. If appropriate, start the pump.

Alarm / Message	Alarm Priority	Description / Corrective Action
Upstream occlusion. Clear occlusion between pump and reservoir.	High	Fluid is not flowing from the fluid container to the pump, which may be due to a kink, closed clamp, or air bubble in the tubing between the fluid container and pump. Delivery is paused and will resume if the occlusion is removed. Remove the obstruction to resume operation. The alarm will clear when the occlusion is removed. You must acknowledge this alarm after it clears if it has occurred and cleared more than 3 times within 15 minutes. Note: This alarm has associated help screens.

WARNING:

- A hazard can exist if different alarm styles are used on multiple pumps in the same single care area, for example, a critical care area or operating room. Auditory alarm signal sound levels that are less than ambient levels can hinder operator recognition of alarm conditions.
- Always set the Delivery Limit amount alarm, Reservoir Volume Low alarm, and all other variable alarm settings to clinically appropriate settings. Setting alarm limits to values not clinically safe for the patient may cause patient harm due to a delay in therapy.

Note: The measured audible alarm sound pressure level range, as tested in accordance with IEC 60601_1_8, is 53 (±4) dBA for high priority alarms and 50 (±4) dBA for medium priority alarms.

Cleaning and Disinfecting the Pump and Accessories

WARNING:

- The pump and reusable accessories should be cleaned and disinfected after each patient use and in accordance with this manual and your organization's policies and procedures for reusable, solid surface, non-critical medical devices. Failure to do so could result in serious patient injury or death.
- Ensure that debris is not allowed to build up on the pressure plate surface of the pumping mechanism. Inspect the air detector sensor slot and remove any debris. A blocked air detector sensor may not detect air present in the fluid path, which could result in serious patient injury or death.

CAUTION:

- Do not immerse the pump in cleaning fluid or water. Do not allow solution to soak into the pump, accumulate on the keypad, or enter the battery compartment, USB port, remote dose cord jack, or power jack areas. Moisture buildup inside the pump may damage the pump.
- Do not oversaturate the chassis area on the bottom of the pump with cleaning or disinfecting solutions. Oversaturating this area can cause damage to the pump sensors over time.
- Do not clean the pump with acetone, other plastic solvents, or abrasive cleaners, as damage to the pump may occur. Also refer to the instructions for use for each accessory before proceeding with cleaning and disinfecting. Some accessories may have their own list of acceptable cleaning and disinfecting solutions.

Note: Refer to the instructions for use for each accessory before proceeding with cleaning.

For optimal efficiency, it is recommended best practice to clean first and then disinfect. All disinfectants require pre-cleaning, except for disinfectant cleaners that are tested to disinfect in the presence of 5% of organic matter.

1. **Inspect the Downstream Occlusion (DSO) seal for damage or wear to the rubber material during cleaning and at each preventative maintenance service.** DSO seals that show signs of cracking or abrasion(s) should be returned to a Smiths Medical Service Center for replacement of the DSO seal, sensor, and bezel.

If the DSO seal does not have cracking and/or abrasion(s), continue with the following steps to clean and disinfect the pump and accessories, unless otherwise specified in the instructions for use for an accessory:

2. **Clean the pump and its accessories using a mild detergent soap solution to remove residuals or contaminated material.** Apply solution to a soft, lint-free cloth and then wipe the pump or accessory. *Do not allow the solution to soak into the pump or accessory.*
3. **Disinfect the pump and its accessories by applying a disinfecting solution (listed below) according to the disinfecting product label instructions.** If using a liquid or spray, apply solution to a soft, lint-free cloth and then wipe the pump or accessory. Follow the disinfectant manufacturer's recommendations for disinfectant contact times. *Do not allow the solution to soak into the pump or accessory.*

Acceptable disinfecting solutions for the CADD[®]-Solis pump and its accessories are listed below.

Note: For the CADD[®]-Solis LockBox, use only the Sani-Cloth[®] Bleach product listed below as other products may affect the transparency of the lockbox.

Product	Manufacturer	EPA Registration Number	Active Ingredient(s)	Contact/Kill Time
CaviWipes™ (Do not use with CADD [®] -Solis LockBox)	Metrex	46781-8	17.2% Isopropanol	3 minutes
Sani-Cloth [®] Super (Do not use with CADD [®] -Solis LockBox)	PDI	9480-4	Dimethyl Benzyl Ammonium Chloride, Dimethyl Ethyl Benzyl Ammonium Chloride	2 minutes
Sani-Cloth [®] Bleach	PDI	9480-8	0.60% Sodium Hypochlorite	4 minutes

4. **Allow the pump and accessories to dry completely before use.**

Radiation and Magnetic Resonance Imaging (MRI)

CAUTION:

- The pump should *not* be directly irradiated by therapeutic levels of ionizing radiation due to the risk of permanent damage to the electronic circuitry. The best procedure to follow is to remove the pump from the patient during therapeutic radiation sessions or diagnostic levels of radiographic and fluoroscopic radiation. If the pump must remain in the vicinity during a diagnostic or therapy session, it should be shielded, and its ability to function properly should be confirmed following treatment.
- Do not expose the pump directly to ultrasound, as permanent damage to the electronic circuitry may occur.
- Magnetic fields produced by MRI equipment may adversely affect the operation of the pump. Remove the pump from the patient during MRI procedures and keep it at a safe distance from magnetic energy. Exposing the pump to strong magnetic fields may cause irreversible damage, rendering the pump inoperable.
- Use of this pump on patients monitored by electronic equipment may cause artifactual interference. As with all electronic equipment, electrical artifacts which affect the performance of other equipment, such as ECG monitors, can occur. The user should check the correct function of the equipment prior to use.
- Do not use the pump in hyperbaric chambers as they affect how the pump works and may also cause damage to the pump.

Standards used in development of the pump

The following standards were used in whole or part in the development of the pump.

Medical Electrical Equipment

EN 60601-1 (2006 + A1:2013 + A11:2011 + A12:2014) Ed3.1, Medical Electrical Equipment, Part I: General Requirements for Safety. Amendment A1 (1993) Amendment A13 (1996) Amendment A2 (1995).

EN 60601-2-24 (2015), Medical Electrical Equipment, Part 2-24: particular Requirements for Safety of Infusion Pumps and Controllers.

EN 60601-1-11 (2010), Medical electrical equipment - Part 1-11: General requirements for basic safety and essential performance - Collateral standard: Requirements for medical electrical equipment and medical electrical systems used in the home healthcare environment

IEC 60601-1 (2005 + A1:2012) Ed3.1, Medical Electrical Equipment, Part 1: General Requirements for Safety. Amendment 1 (1991) Amendment 2 (1995).

IEC 60601-2-24 (2012), Medical Electrical Equipment, Part 2-24: Particular Requirements for Safety of Infusion Pumps and Controllers.

IEC 60601-1-11 (2015), Medical electrical equipment - Part 1-11: General requirements for basic safety and essential performance - Collateral standard: Requirements for medical electrical equipment and medical electrical systems used in the home healthcare environment

CAN/CSA-C22.2 601.1-M90, Medical Electrical Equipment, Part 1: General Requirements for Safety - November 1990 (Canadian Deviations to IEC 60601-1) Update No. 2 (November 2003).

ANSI/AAMI ES60601-1 (2005/(R2012) + A1:2012) Ed 3.1, Medical electrical equipment - Part 1: General requirements for basic safety and essential performance

IEC 60601-1-8 (2012), Medical electrical equipment - Part 1-8: General requirements for basic safety and essential performance - Collateral Standard: General requirements, tests and guidance for alarm systems in medical electrical equipment and medical electrical systems

EN 60601-1-8 (2007 + AC:2010), Medical electrical equipment - Part 1-8: General requirements for basic safety and essential performance - Collateral Standard: General requirements, tests and guidance for alarm systems in medical electrical equipment and medical electrical systems

IEC 62304 (2015), Medical device software - Software life-cycle processes

EN 62304 (2006 + AC:2008), Medical device software - Software life-cycle processes

Electromagnetic Compatibility

RTCA/DO -160G (2010), Radiated Emissions Only, Category M Limit.

EN 60601-1-2 (2015), Medical Electrical Equipment, Part 1-2: General Requirements for Safety - Collateral Standard: Electromagnetic Compatibility - Requirements and Tests.

IEC 60601-1-2 (2014), Medical Electrical Equipment, Part 1-2: General Requirements for Safety - Collateral Standard: Electromagnetic Compatibility - Requirements and Tests.

CISPR11 (2004), Limits and methods of measurement of electromagnetic disturbance characteristics of industrial, scientific and medical (ISM) radio frequency equipment. Amendment 1 (1999) Amendment 2 (2002).

Miscellaneous Standards

IEC 60529 (2001), Degrees of protection provided by enclosures (IP Code).

EU RoHS Directive 2011/65/EU, Restriction of Hazardous Substances in Electrical and Electronic Equipment

REACH Regulation (EC) No.1907/2006, Registration, Evaluation, and Authorization of Chemicals (REACH)

2012/19/EU, Waste Electrical and Electronic Equipment (WEEE)

Essential Performance

The CADD®-Solis pump has the following essential performance characteristics:

The pump delivery will be at the set rate within the declared limits of accuracy under nominal conditions or will provide an alarm.

The pump high priority alarms will remain operable.

The following pump protective systems will be operable or alarm:

- Pump Clock Self-Test
- Motor Safety Circuit Test
- Disposable Detection
- Air Detection
- Occlusion Detection
- Latch/Lock Sensors

PCA Delivery Mode Scroll Ranges

PCA Continuous Rate Scroll Ranges			
Units	Starting Value	Increment	Maximum
Milliliters	0	0.10	100.00
Milligrams only	10% of concentration	Values between 0.01 and 0.5: 0.01	Concentration x 100
Micrograms only	10% of concentration	Values between 0.1 and 0.5: 0.1	Concentration x 100
Milligrams and Micrograms	10% of concentration	Values between 0.5 and 100: 0.1	Concentration x 100
		Values between 100 and 1000: 1.0	
		Values greater than 1000: 10.0	

PCA Dose and Clinician Bolus Scroll Ranges			
Units	Starting Value	Increment	Max.
Milliliters	0	0.05	50

PCA Dose and Clinician Bolus Scroll Ranges: Milligrams					
Concentration (mg/mL)	Increment (mg)	Max. (mg)	Concentration (mg/mL)	Increment (mg)	Max. (mg)
0.1	0.01	5	20	1.00	1000
0.2	0.02	10	25	1.25	1250
0.3	0.03	15	30	1.50	1500
0.4	0.04	20	35	1.75	1750
0.5	0.05	25	40	2.00	2000
1	0.05	50	45	2.25	2250
2	0.10	100	50	2.50	2500
3	0.15	150	55	2.75	2750
4	0.20	200	60	3.00	3000
5	0.25	250	65	3.25	3250
6	0.30	300	70	3.50	3500
7	0.35	350	75	3.75	3750
8	0.40	400	80	4.00	4000
9	0.45	450	85	4.25	4250
10	0.50	500	90	4.50	4500
11	0.55	550	95	4.75	4750
12	0.60	600	100	5.00	5000
13	0.65	650			
14	0.70	700			
15	0.75	750			

PCA Dose and Clinician Bolus Scroll Ranges: Micrograms					
Concentration (mcg/mL)	Increment (mcg)	Max. (mcg)	Concentration (mcg/mL)	Increment (mcg)	Max. (mcg)
1	0.05	50	35	1.75	1750
2	0.10	100	40	2.00	2000
3	0.15	150	45	2.25	2250
4	0.20	200	50	2.50	2500
5	0.25	250	55	2.75	2750
6	0.30	300	60	3.00	3000
7	0.35	350	65	3.25	3250
8	0.40	400	70	3.50	3500
9	0.45	450	75	3.75	3750
10	0.50	500	80	4.00	4000
11	0.55	550	85	4.25	4250
12	0.60	600	90	4.50	4500
13	0.65	650	95	4.75	4750
14	0.70	700	100	5.00	5000
15	0.75	750	200	10.00	10,000
20	1.00	1000	300	15.00	15,000
25	1.25	1250	400	20.00	20,000
30	1.50	1500	500	25.00	25,000

Military Time

Military Time Conversion					
12-Hour Time		24-Hour Time	12-Hour Time		24-Hour Time
12:00 AM	MIDNIGHT	00:00	12:00 PM	NOON	12:00
1:00 AM		01:00	1:00 PM		13:00
2:00 AM		02:00	2:00 PM		14:00
3:00 AM		03:00	3:00 PM		15:00
4:00 AM		04:00	4:00 PM		16:00
5:00 AM		05:00	5:00 PM		17:00
6:00 AM		06:00	6:00 PM		18:00
7:00 AM		07:00	7:00 PM		19:00
8:00 AM		08:00	8:00 PM		20:00
9:00 AM		09:00	9:00 PM		21:00
10:00 AM		10:00	10:00 PM		22:00
11:00 AM		11:00	11:00 PM		23:00

Specifications (Nominal)

General Pump Specifications

System definition	CADD [®] -Solis pump with 1 of the following attached: <ul style="list-style-type: none"> • CADD[®] administration set with Flow Stop feature • CADD[®] high volume administration set with Flow Stop feature
Used to test the pump	<ul style="list-style-type: none"> • CADD[™] medication cassette reservoirs, REF 21-7002, 21-7308, 21-7302 • CADD[®] extension sets, REF 21-7045, 21-7046, 21-7047 • CADD[®] administration sets, REF 21-7091, 21-7034, 21-7021, 21-7321 • CADD[®] high volume administration sets, REF 21-7057, 21-7357
Resolution	<ul style="list-style-type: none"> • CADD[™] medication cassette reservoir: 0.050 mL per pump stroke nominal • CADD[®] administration set: 0.050 mL per pump stroke nominal • CADD[®] high volume administration set: 0.1 mL per pump stroke nominal
Size	Excluding cassette and accessories: 4.1 cm × 10.2 cm × 12.7 cm 1.6 in × 4 in × 5 in
Weight	Including 4 AA alkaline batteries, excluding other accessories: 595 g 21 oz
Maximum surface Temperature (pump, while operating)	48°C (118°F) Maximum
Expected Service Life	5 years
Pump alarms	<ul style="list-style-type: none"> • High priority alarms: Air in line detected, Battery depleted while delivering, Battery removed while delivering, Battery unusable while delivering, Disposable attached improperly, Disposable detached while delivering, Disposable locked but not latched, Disposable type high flow administration set not allowed, Disposable type high flow administration set required, Disposable type invalid, Downstream occlusion, Key stuck, Pressure sensor faulty, Pump automatically stopped, Rechargeable battery end of life, Remote dose cord key stuck, Reservoir volume empty, Stop mode reminder, Upstream occlusion • Medium priority alarms: 23 • Low priority alarms: 10 • Informational messages/alerts 23
Battery fallout alarm	Alarm sounds for 2 minutes if the pump has been powered up for a minimum of 4 minutes. Note: Alarm enabled while pump is in run mode only.

Battery status	Battery State	CADD®-Solis Pump Status
	25% to 100%	No alarm
Low battery	<ul style="list-style-type: none"> • Transition to low battery condition • Battery low message appears • Pump emits 3 beeps every 5 min • Low battery warning message appears on pump display • Pump is operable • LCD backlight flashes for 12 ms during each motor operation 	
Depleted battery	<ul style="list-style-type: none"> • Transition to depleted battery condition • Battery depleted message appears • Pump emits a continuous, variable-tone alarm • Depleted battery warning message appears on pump display • Battery power is too low to operate pump • Pump delivery operation stops 	
Shut down	Pump shuts off due to too low operating voltage.	

Alkaline battery life with screen backlight intensity set to 3 Continuous and PCA delivery (Max. delivery rate = 100 mL/hr)	These estimates are based on laboratory tests conducted at room temperature using new batteries (Duracell® PC1500/MN1500, IEC LR6). Actual battery life varies depending on the battery brand, shelf life, temperature conditions, delivery rate, and frequency of screen display and backlighting. It is recommended that new batteries be kept available for replacement.						
	Delivery Rate (mL/hr)		Operating Time (hrs)			Vol. Delivered (mL)	
	0.4		142			56	
	1		139			139	
	5		124			620	
	10		113			1130	
	30		69			2070	
	50		59			2950	
	125		37			4625	
	200		29			5800	
	350		15			5250	
500		11			5500		
Intermittent delivery	Volume (mL)	Duration (hr)	Cycle (hr)	KVO (mL/hr)	Operating Time (hrs)	Vol. Delivered (mL)	
	20.2	1	4	0.2	131	684	
	40.7	1	4	0.2	116	1221	
	61	1	6	0.2	111	1177	
	125	1	6	0.2	75	1637	
	200	1	12	0.2	111	2020	
Step delivery	Volume to Deliver (mL)	Starting Rate (mL/hr)	Step Duration (min)	Step Rate Increase (mL/hr)	Max Rate (mL/hr)	No. of Steps	Operating Time (hrs)
	900	45	15	45	315	7	23
	1500	37.5	30	80	300	5	24
	2500	30	30	90	300	4	19
Taper delivery	Volume (mL)	Period (hr)	Taper Up (hr)	Taper Down (hr)	KVO (mL/hr)	Operating Time (hrs)	Vol. Delivered (mL)
	2000	12	1	1	5	31	5800
	3000	12	1	1	5	23	6460

Rechargeable battery pack life with screen backlight intensity set to 3 Continuous and PCA delivery (Max. delivery rate = 100 mL/hr)	These estimates are based on laboratory tests conducted at room temperature using a new CADD [®] -Solis rechargeable battery pack. Actual battery life varies depending on temperature conditions, delivery rate, and frequency of screen display and backlighting. It is recommended that new batteries be kept available for replacement.						
	Rate (mL/hr)		Life (hrs)		Volume (mL)		
	0.4		74		29		
	1		67		67		
	5		60		300		
	10		50		500		
	30		40		1200		
	50		35		1750		
	125		30		3750		
	200		20		4000		
	350		13		4550		
	500		10		5000		
Intermittent delivery	Volume (mL)	Duration (hr)	Cycle (hr)	KVO (mL/hr)	Operating Time (hrs)	Vol. Delivered (mL)	
	20.2	1	4	0.2	81	436	
	40.7	1	4	0.2	68	702	
	61	1	6	0.2	85	929	
	125	1	6	0.2	53	1133	
	200	1	12	0.2	95	2424	
Step delivery	Volume to Deliver (mL)	Starting Rate (mL/hr)	Step Duration (min)	Step Rate Increase (mL/hr)	Max Rate (mL/hr)	No. of Steps	Operating Time (hrs)
	900	45	15	45	315	7	17
	1500	37.5	30	80	300	5	17
	2500	30	30	90	300	4	15
Taper delivery	Volume (mL)	Period (hr)	Taper Up (hr)	Taper Down (hr)	KVO (mL/hr)	Operating Time (hrs)	Vol. Delivered (mL)
	2000	12	1	1	5	21	3830
	3000	12	1	1	5	17	4640
Classification	CF <input checked="" type="checkbox"/> Class II <input type="checkbox"/>						
Moisture protection	Splashproof (IP24) per IEC 60529						
Maximum infusion pressure	1.86 bar 27.0 psi						

Maximum time to occlusion alarm and Bolus volume at occlusion alarm	Flow Rate (mL/hr)	Tubing Set	Max. Time to Occlusion		Bolus at Occlusion	
			Raw Test Data (min)	Spec. (min)	Raw Test Data (mL)	Spec. (mL)
	0.1	CADD™ medication cassette reservoir [REF] 21-7002 with CADD® extension set [REF] 21-7045	90	≤ 160	0.107	≤ 0.25
		CADD® administration set [REF] 21-7091	122	≤ 190	0.139	≤ 0.30
		CADD® high volume administration set [REF] 21-7055	1140	≤ 1200	1.250	≤ 1.40
	Flow Rate (mL/hr)	Tubing Set	Max. Time to Occlusion		Bolus at Occlusion	
			Raw Test Data (sec)	Spec. (sec)	Raw Test Data (mL)	Spec. (mL)
	150	CADD™ medication cassette reservoir [REF] 21-7002 with CADD® extension set [REF] 21-7045	4	≤ 45	0.069	≤ 0.25
CADD® administration set [REF] 21-7091		4	≤ 45	0.072	≤ 0.30	
CADD® high volume administration set [REF] 21-7055		32	≤ 90	1.059	≤ 1.40	
Power sources	<ul style="list-style-type: none"> • AC adapter • CADD®-Solis rechargeable battery pack • Four AA alkaline batteries (for example, Duracell® PC1500/MN1500, IEC LR6) 					
Charging system for internal memory backup battery	The internal memory backup battery uses lithium manganese dioxide technology. It charges whenever the pump is powered on and has a 10-month memory capacity once it has been charged for 250 hours at 20°C (68°F).					
System operating temperature	2°C to 40°C 36°F to 104°F					
System storage and transportation temperature	-20°C to 60°C -4°F to 140°F					
Relative humidity	20% to 90% relative humidity, non-condensing					
Atmospheric pressure	70 kPa to 106 kPa 10.2 psi to 15.4 psi					

System delivery accuracy**± 6% at Nominal Conditions**

At low infusion rates, this accuracy may not be achieved for short periods. During the total infusion time, the accuracy averages out.

System delivery accuracy is determined under the following nominal conditions:

- Infusion rates of both 10 mL/hr and 150 mL/hr
- Ambient temperature of 22 degree C
- Fluid viscosity of 0.89 cP (i.e., water)
- 0.2 mmHg (0.004 PSI) back pressure (i.e., 2 inch 18Ga needle)
- Pump and Reservoir both placed at the same height as the infusion site

Accuracy testing was performed using 22 CADD®-Solis ambulatory infusion pumps and 22 CADD® administration sets with Flow Stop (i.e., 21-7321-24) and 22 CADD® high volume administration sets with Flow Stop free flow protection (i.e., 21-7357-24).

WARNING:

- Ensure that the ± 6% system delivery accuracy specification is taken into account when programming the pump and/or filling the reservoir. Failure to do so may result in medication in the reservoir becoming depleted sooner than expected. If the pump is being used to deliver critical or life sustaining medication, the interruption in the delivery of medication could result in patient injury or death.
- System delivery inaccuracies beyond ± 6% may occur as a result of back pressure or fluid resistance, which depends upon temperature, drug viscosity, catheter size, extension set tubing (for example, microbore), in-line components (such as filters and needleless access connectors), and placing the infusion reservoir and/or pump above or below the level of the patient. System delivery inaccuracy may result in under or overdosing of medication.

Alternate System Configurations at Nominal Conditions	System Delivery Accuracy
Flow Stop administration set with air eliminating filter (0.2 µm and 1.2 µm) at 10 mL/hr	-8% to 8%
Non-Flow Stop administration set at 10 mL/hr	-9% to 2%
High volume Flow Stop administration set with air eliminating filter (0.2 µm and 1.2 µm) at 150 mL/hr	-7% to 8%
High volume non-Flow Stop administration set at 150 mL/hr	-7% to 4%
All 50/100 mL medication cassette reservoirs at 10 mL/hr	-9% to 11%
All 250 ml medication cassette reservoirs at 10 mL/hr	-13% to 8%

Patient Selection

It is important to consider patient selection with regard to clinical factors and environmental factors. These factors can include the route of administration, the prescribed medication, and the system configuration chosen to ensure acceptable delivery accuracy is appropriate for your patient.

For example, when delivering highly viscous medications (e.g., select antibiotics or TPN formulations) at higher rates (e.g., 150 mL/hr), consider using the CADD® high volume administration set 21-7381-24, which includes a 1.2 µm filter.

Challenge Conditions

The adjusted flow rate accuracy for non-nominal environmental conditions when using a CADD® standard and high volume administration set with Flow Stop free flow protection is summarized below as determined per testing methods defined in industry standard IEC 60601-2-24.

Challenge Conditions	Administration set at 10 mL/hr	High volume administration set at 150 mL/hr
Pump & reservoir height approximately four feet below the infusion site (backpressure increase of 100mmHg)	-12% to 7%	-4% to 4%
Pump & reservoir height approximately four feet above the infusion site (backpressure decrease of 100mmHg)	-6% to 11%	1% to 14%
Temperature at 2°C, 20% RH	-12% to -1%	-10% to -1%
Temperature at 40°C, 90% RH	-10% to 10%	-8% to 17%
Viscosity of 5.12 cP (50% Water / 50% Dextrose Solution)	-20% to 2%	N/A

Bolus accuracy specification: ± 6% Tested with CADD® administration set with Flow Stop free flow protection	Nominal condition test data for bolus accuracy at 0.05 mL:	
	Average	0.0508 mL
	% Error	1.6%
	Minimum Error %	-3.0%
	Maximum Error %	4.2%
	Nominal condition test data for bolus accuracy at 50 mL:	
	Average	50.77 mL
	% Error	1.55%
	Minimum Error %	-0.07%
	Maximum Error %	2.35%
	Challenge test conditions:	
	0.05 mL at 2°C, 20% RH	-14% to -1%
	0.05 mL at 40°C, 90% RH	-1% to 12%
	50 mL at 2°C, 20% RH	-16% to -7%
50 mL at 40°C, 90% RH	-8% to 2%	
High pressure alarm threshold	1.24 bar ± 0.62 bar 18 psi ± 9 psi	
Air detector alarm	Sensitivity: • Low: Single bubble > 400 µL • High: Single bubble > 150 µL Accumulated Air: Greater than 1 mL air over 15 minutes (nominal)	
Maximum volume infused under single-fault conditions	• CADD® administration set: 0.15 mL • CADD® high volume administration set: 0.30 mL	
Delivery rate during priming	• Standard volume administration set: approx. 250 mL/hr • High volume administration set: approx. 500 mL/hr	
Alarm disabled during priming	Air-In Line	

Configurable Specifications

General Specifications	
Reservoir volume	0 to 9999 Programmable in 1 mL increments Displayed in 0.1 mL increments
Given	0 to 99,999.99 in 0.01 unit increments
Res vol low trip point	1 to 999 mL in increments of 1 mL
Res vol empty alarm	<ul style="list-style-type: none"> Insistent and one time only Non-insistent and repeating
Delayed start	0 to 96 hr in 5 min increments
Pump stopped alarm	<ul style="list-style-type: none"> Informational High priority
Air detector	<ul style="list-style-type: none"> On Off
Air detector sensitivity	Low Sensitivity: Single bubble > 400 μ L High Sensitivity: Single bubble > 150 μ L
Alarm volume	<ul style="list-style-type: none"> High Medium Low
PM (preventive maintenance) reminder	Interval: 1 to 24 months in 1 month increments Enable: On or Off
Custom keypad code	001 to 899 in increments of 1
Custom clinician code	001 to 899 in increments of 1
Custom administrator code	001 to 899 in increments of 1
Date format	<ul style="list-style-type: none"> US standard (month/day/year) European standard (day/month/year) International standard ISO 8601:2004 (year/month/day)
Time format	<ul style="list-style-type: none"> 00:00 to 23:59 military 12-hour AM/PM
Downstream occlusion sensitivity	High Sensitivity: When the high pressure alarm threshold is reached, the downstream occlusion alarm is triggered immediately. Low Sensitivity: When the high pressure alarm threshold is reached, the downstream occlusion alarm is delayed for 2 seconds. This allows for the pressure to stabilize before a possible alarm. If the pressure stabilizes below the high pressure alarm threshold before the 2 second delay is complete, the alarm will not occur.
Upstream occlusion sensor	<ul style="list-style-type: none"> On Off <p>Note: The upstream occlusion sensor is automatically disabled during use with medication cassette reservoirs.</p>

PCA Delivery Specifications	
Programming units	<ul style="list-style-type: none"> • Milliliters (mL) • Milligrams (mg) • Micrograms (mcg)
Concentration	<p>mg/mL:</p> <ul style="list-style-type: none"> • 0.1 to 0.5 mg/mL in increments of 0.1 mg/mL • 0.5 to 1 mg/mL in increments of 0.5 mg/mL • 1 to 15 mg/mL in increments of 1 mg/mL • 15 to 100 mg/mL in increments of 5 mg/mL <p>mcg/mL:</p> <ul style="list-style-type: none"> • 1 to 15 mcg/mL in increments of 1 mcg/mL • 15 to 100 mcg/mL in increments of 5 mcg/mL • 100 to 500 mcg/mL in increments of 100 mcg/mL
Continuous rate	0 to 100 mL/hr (or the mg or mcg equivalent)
PCA dose	0 mL to 50 mL (or the mg or mcg equivalent) Max delivery rate (continuous rate + PCA dose): 40 to 250 mL/hr
PCA dose lockout	1 minute to 24 hours in the following increments: <ul style="list-style-type: none"> • 1 minute for values between 1 and 20 minutes • 5 minutes between 20 minutes and 24 hours
Max doses per hour	1 to 60
Delivery limit amount	0.1 to 1900 mL (or the mg or mcg equivalent) in increments of: <ul style="list-style-type: none"> • 0.01 mL from 0.1 to 0.5 mL • 0.1 mL from 0.5 to 100 mL • 1 mL from 100 to 1,000 mL • 10 mL from 1,000 to 1,900 mL
Clinician bolus	0 to 50 mL (or mg or mcg equivalent)
Delivery limit method	<ul style="list-style-type: none"> • Delivery limit • Max doses per hour • Not in use
Delivery limit period	1 to 12 hours in increments of 1 hour
Max delivery rate, combined bolus and continuous rate	40 to 250 mL/hr in increments of 1 mL
KVO rate	<ul style="list-style-type: none"> • 0 mL/hr • 0.1 mL/hr

Continuous Delivery Specifications	
Continuous rate	0.1 to 500 mL/hr
KVO rate	0.1 to 10 mL/hr

Intermittent Delivery Specifications	
Dose volume	0.1 to 1000 mL
Dose duration	1 min to 24 hr
Dose cycle	10 min to 96 hr
Next dose start time	0 to 96 hr in 5 min increments
KVO rate	0 to 10 mL/hr

Step Delivery Specifications	
Initial rate	0.4 to 499 mL/hr
Plateau rate	0.4 to 500 mL/hr
Rate increment	0.4 to 499 mL/hr
Infusion volume	1 to 9990 mL
Step duration	15 min to 24 hr
KVO rate	0 to 10 mL/hr
Step infusion alerts	<ul style="list-style-type: none"> • On • Off

Taper Delivery Specifications	
Infusion volume	1 to 9990 mL
Taper up	0 min to 99:40 hr:min
Taper down	0 min to 99:40 hr:min
Infusion duration	10 min to 99:50 hr:min
KVO rate	0 to 10 mL/hr
Plateau rate upper limit	0.1 to 500 mL/hr

CADD™ Ambulatory Tubing Set Testing	
One representative medication for each of the following routes of delivery was tested for drug interaction with pump disposables. Use any selected drug in accordance with the indications included in the drug package insert. Administration of any drug by the CADD®-Solis VIP ambulatory infusion pump is limited by any warnings, precautions, or contraindications in the drug labeling.	
Route of Delivery	Drug Tested
Intravenous, subarachnoid space (intrathecal)	Morphine Sulfate Injection
Intra-arterial	Floxuridine for Injection, USP
Intraperitoneal	Dianeal with dextrose
Epidural space, local infiltration (subcutaneous, perineural, surgical site)	Ropivacaine HCl Injection

Electromagnetic Emissions and Immunity Declarations

Guidance and Manufacturer's Declaration—Electromagnetic Emissions		
The CADD®-Solis pump is intended for use in the electromagnetic environment specified below. The customer or the user of the CADD®-Solis pump should assure that it is used in such an environment.		
Emissions Test	Compliance	Electromagnetic Environment—Guidance
RF emissions CISPR 11	Group 1	The Pump uses RF energy only for its internal function. Therefore, its RF emissions are very low and are not likely to cause any interference in nearby electronic equipment.
RF emissions CISPR 11	Class B	The Pump is suitable for use in all establishments, including domestic establishments and those directly connected to the public low-voltage power supply network that supplies buildings used for domestic purposes.
Harmonic emissions IEC 61000-3-2	Not applicable	
Voltage fluctuations/ flicker emissions IEC 61000-3-3	Not applicable	

Compliance using: 100–240 VAC 50/60 Hz to 7 VDC switching AC adapter, with an AC power cord length of 1.8 m (6 ft), rechargeable battery pack, remote dose cord with a length of 152 cm ± 5 cm (60 in ± 2 in), and a USB cable length of less than 2 m (6.5 ft).

WARNING:

- The use of power supplies and a remote dose cord other than those listed in the electromagnetic emissions declaration may result in increased emissions or decreased immunity of the pump.
- The pump should not be used adjacent to or stacked with other equipment. If adjacent or stacked use is necessary, you should verify normal operation of the pump in the configuration in which it is to be used.
- Common portable and mobile consumer electronic devices may cause interference with the pump. Observe the pump to verify normal operation. If abnormal performance is observed, it may be necessary to reorient or relocate the pump away from radio frequency transmitting devices.
- Residential/facility wiring must comply with all applicable electrical codes. Do not bypass power cord connections. Do not remove a prong from the power cord. Failure to comply may result in fire or electrical shock.

Guidance and Manufacturer's Declaration—Electromagnetic Immunity			
The CADD®-Solis pump is intended for use in the electromagnetic environment specified below. The customer or user of the CADD®-Solis pump should assure that it is used in such an environment.			
Immunity Test	IEC 60601 Test Level	Compliance Level	Electromagnetic Environment—Guidance
Electrostatic discharge (ESD) IEC 61000-4-2	± 6 kV contact ± 8 kV air	± 8 kV contact ± 15 kV air (IEC 60601-2-24)	Floors should be wood, concrete, or ceramic tile. If floors are covered with synthetic material, the relative humidity should be at least 30%.
Electrical fast transient/burst IEC 61000-4-4	± 2 kV for power supply lines ± 1 kV for input/output lines	± 2 kV for power supply lines Not applicable	Mains power quality should be that of a typical commercial or hospital environment.
Surge IEC 61000-4-5	± 1 kV line(s) to line(s) ± 2 kV line(s) to earth	± 1 kV line(s) to line(s) ± 2 kV line(s) to earth	Mains power quality should be that of a typical commercial or hospital environment.
Voltage dips, short interruptions, and voltage variations on power supply input lines IEC 61000-4-11	< 5% U_t (> 95% dip in U_t) for 0.5 cycle 40% U_t (60% dip in U_t) for 5 cycles 70% U_t (30% dip in U_t) for 25 cycles < 5% U_t (> 95% dip in U_t) for 5 sec	< 5% U_t (> 95% dip in U_t) for 0.5 cycle 40% U_t (60% dip in U_t) for 5 cycles 70% U_t (30% dip in U_t) for 25 cycles < 5% U_t (> 95% dip in U_t) for 5 sec	Mains power quality should be that of a typical commercial or hospital environment. If the user of the Pump requires continued operation during power mains interruptions, it is recommended that the Pump be powered from an uninterruptible power supply or a battery.
Power frequency 50/60 Hz magnetic field IEC 61000-4-8	3 A/m	400 A/m (IEC 60601-2-24)	Power frequency magnetic fields should be at levels characteristic of a typical location in a typical commercial or hospital environment.
Note: U_t is the a.c. mains voltage prior to application of the test level.			

Guidance and Manufacturer's Declaration—Electromagnetic Immunity			
The CADD®-Solis pump is intended for use in the electromagnetic environment specified below. The customer or user of the CADD®-Solis pump should assure that it is used in such an environment.			
Immunity Test	IEC 60601 Test Level	Compliance Level	Electromagnetic Environment—Guidance
			Portable and mobile RF communications equipment should be used no closer to any part of the Pump, including cables, than the recommended separation distance calculated from the equation applicable to the frequency of the transmitter.
Conducted RF IEC 61000-4-6	3 Vrms 150 kHz to 80 MHz outside ISM bands ^a	3 Vrms	Recommended separation distance $d = 1.2 \sqrt{P}$
Conducted RF IEC 61000-4-6	10 Vrms 150 kHz to 80 MHz in ISM bands ^b	10 Vrms	Recommended separation distance $d = 1.2 \sqrt{P}$
Radiated RF IEC 61000-4-3	10 V/m 80 MHz to 2.5 GHz	10 V/m	$d = 1.2 \sqrt{P}$ 80 MHz to 800 MHz $d = 2.3 \sqrt{P}$ 800 MHz to 2.5 GHz
			Where P is the maximum output power rating of the transmitter in watts (W) according to the transmitter manufacturer and d is the recommended separation distance in meters (m). ^c Field strengths from fixed RF transmitters, as determined by an electromagnetic site survey, ^c should be less than the compliance level in each frequency range. ^d Interference may occur in the vicinity of equipment marked with the following symbol: 
<p>Note 1: At 80 MHz and 800 MHz, the higher frequency range applies.</p> <p>Note 2: These guidelines may not apply in all situations. Electromagnetic propagation is affected by absorption and reflection from structures, objects, and people</p>			
<p>^a The ISM (industrial, scientific, and medical) bands between 150 kHz and 80 MHz are 6.765 MHz to 6.795 MHz; 13.553 MHz to 13.567 MHz; 26.957 MHz to 27.283 MHz; and 40.66 MHz to 40.70 MHz.</p> <p>^b The compliance levels in the ISM frequency bands between 150 kHz and 80 MHz and in the frequency range 80 MHz to 2.5 GHz are intended to decrease the likelihood that mobile/portable communications equipment could cause interference if it is inadvertently brought into patient areas. For this reason, an additional factor of 10/3 is used in calculating the recommended separation distance for transmitters in these frequency ranges.</p> <p>^c Field strengths from fixed transmitters, such as base stations for radio (cellular/cordless) telephones and land mobile radios, amateur radio, AM and FM radio broadcast and TV broadcast cannot be predicted theoretically with accuracy. To assess the electromagnetic environment due to fixed RF transmitters, an electromagnetic site survey should be considered. If the measured field strength in the location in which the CADD®-Solis pump is used exceeds the applicable RF compliance level above, the CADD®-Solis pump should be observed to verify normal operation. If abnormal performance is observed, additional measures may be necessary, such as reorienting or relocating the CADD®-Solis pump.</p> <p>^d Over the frequency range 150 kHz to 80 MHz, field strengths should be less than 3 V/m.</p>			

Recommended separation distances between portable and mobile RF communications equipment and the CADD®-Solis pump				
The CADD®-Solis pump is intended for use in an electromagnetic environment in which radiated RF disturbances are controlled. The customer or the user of the CADD®-Solis pump can help prevent electromagnetic interference by maintaining a minimum distance between portable and mobile RF communications equipment (transmitters) and the CADD®-Solis pump as recommended below, according to the maximum output power of the communications equipment.				
Rated maximum output power or transmitter W	Separation distance according to frequency of transmitter m			
	150 kHz to 80 MHz outside ISM bands $d = 1.2\sqrt{P}$	80 MHz to 800 MHz in ISM bands $d = 1.2\sqrt{P}$	80 MHz to 800 MHz $d = 1.2\sqrt{P}$	800 MHz to 2.5 GHz $d = 2.3\sqrt{P}$
0.01	0.12	0.12	0.12	0.23
0.1	0.38	0.38	0.38	0.73
1	1.2	1.2	1.2	2.3
10	3.8	3.8	3.8	7.3
100	12	12	12	23

For transmitters rated at a maximum output power not listed above, the recommended separation distance d in meters (m) can be determined using the equation applicable to the frequency of the transmitter, where P is the maximum output power rating of the transmitter in watts (W) according to the transmitter manufacturer.

Note 1: At 80 MHz and 800 MHz, the separation distance for the higher frequency range applies.

Note 2: The ISM (industrial, scientific, and medical) bands between 150 kHz and 80 MHz are 6.765 MHz to 6.795 MHz; 13.553 MHz to 13.567 MHz; 26.957 MHz to 27.283 MHz; and 40.66 MHz to 40.70 MHz.

Note 3: An additional factor of 10/3 is used in calculating the recommended separation distance for transmitters in the ISM frequency bands between 150 kHz and 80 MHz and in the frequency range 80 MHz to 2.5 GHz to decrease the likelihood that mobile/portable communications equipment could cause interference if it is inadvertently brought into patient areas.

Note 4: These guidelines may not apply in all situations. Electromagnetic propagation is affected by absorption and reflection from structures, objects, and people.

Collect Separately

This product contains electrical and electronic components (including batteries) that may contain materials, which if disposed of with general waste, could be damaging to the environment.

In accordance with Directive 2002/96/EC Waste Electrical and Electronic Equipment, residents of the European Union must follow specific disposal or recycling instructions for this product. Contact your local distributor, or visit the following web site for specific instructions:

<http://www.smiths-medical.com/recycle/index.html>.

Non-European Union residents must dispose of or recycle this product (including batteries) in accordance with the local laws or regulations that apply.

WARNING: There are potential health hazards associated with improper disposal of batteries, electronics, and contaminated (used) reservoirs and extension sets. Dispose of used batteries, reservoirs, extension sets, and other used accessories, or a pump that has reached the end of its useful life, in an environmentally safe manner, and according to any regulations that may apply.

Menu Maps

Tasks Menus

Tasks
Reset Reservoir Volume
Taper Down Now (Taper only)
Set Delayed Start (<i>not</i> Intermittent)
Set Next Dose Start Time (Intermittent only)
Prime Tubing
View Delivery Settings
Display and Sound Settings
Change Time and Date
View Reports
View Advanced Tasks

Delivery Settings				
PCA	Continuous	Intermittent	Step	Taper
Units	Continuous Rate	Dose Volume	Infusion Volume	Infusion Volume
Concentration				
Continuous Rate				
PCA Dose		Dose Duration	Initial Rate	Taper Up
PCA Lockout		Dose Cycle	Rate Increment	Taper Down
Delivery Limit		Dose Rate	Plateau Rate	Infusion Duration
Max Doses/Hr		Next Dose	Step Duration	Plateau Rate
		Infusion Duration		
KVO Rate	KVO Rate	KVO Rate	KVO Rate	KVO Rate
Reservoir Vol.	Reservoir Vol.	Reservoir Vol.	Reservoir Vol.	Reservoir Vol.
Start Time	Start Time		Start Time	Start Time

Display and Sound Settings
Backlight Intensity
Alarm Volume
Sound Theme
Key Beep On/Off
Numeric Format

Time and Date
Current Time
Current Date
Time Format
Date Format

Reports
Total Given (<i>not</i> PCA)
Given and PCA Dose Counters (PCA only)
PCA Dose Graph (PCA only)
Delivery History and Pie Chart
Delivery Log
Event Log
Protocol Library Summary
Device Information

Advanced Tasks
Step Down (Step only)
Step Up (Step only)
Give Clinician Bolus (PCA only)
Patient Permissions
Air and Occlusions Settings
Alarm Settings
Security Settings
Start New Patient
Start New Protocol Same Patient
Delivery Hard and Soft Limits
Reset to Factory Settings

Advanced Tasks Menus

Patient Permissions
Priming Security On/Off
Delayed Start Security On/Off

Air and Occlusions Settings
Air Detector On/Off
Air Detector Sensitivity
Upstream Sensor On/Off
Downstream Sensor Sensitivity

Alarm Settings
Infusion Alerts (Step only)
Pump Stopped Alarm Type
Reservoir Low Trip Point
Reservoir Low Alarm Type
Reservoir Empty Alarm Type
PM Reminder On/Off
PM Reminder Interval

Security Settings
Keypad Security
Keypad Code
Clinician Code
Admin Code
Manual Programming Security

Delivery Hard and Soft Limits	
Mode	Settings
PCA	Continuous Rate PCA Dose PCA Lockout Delivery Limit Method Delivery Limit Period Delivery Limit Amount Max Doses/Hr Max Delivery Rate Clinician Bolus Amount
Continuous	Continuous Rate
Intermittent	Dose Volume Dose Duration Dose Cycle
Step	Initial Rate Rate Increment Plateau Rate
Taper	Infusion Volume Max Plateau Rate

Default Factory Settings

The first time you use the pump, the protocol is set to the factory default, which is the **Continuous mode**. You may reset the pump to the factory default settings at any time (see *Reset to Factory Settings* on page 112).

Factory Default Pump Settings (Continuous Mode)	
Submenu	Default Setting
Reset Reservoir Volume	100 mL
View Delivery Settings	(See <i>Manual Mode Initial Delivery Settings</i> , on page 145)
Display and Sound Settings	
Backlight Intensity	3
Alarm Volume	High
Sound Theme	Standard
Key Beep On/Off	On
Numeric Format	1,234.56
Change Time and Date	
Time Format	12:00:00 AM/PM
Date Format	Month/Day/Year
View Advanced Tasks	
Patient Permissions	
Priming Security On/Off	On
Delayed Start Security On/Off	On
Air and Occlusions Settings	
Air Detector On/Off	On
Air Detector Sensitivity	Low
Upstream Sensor On/Off	On
Downstream Sensor Sensitivity	Low
Alarm Settings	
Pump Stopped Alarm Type	Informational
Reservoir Low Trip Point	5 mL
Reservoir Low Alarm Type	Insistent and One Time Only
Reservoir Empty Alarm Type	One Time Only
PM Reminder On/Off	Off
Security Settings	
Keypad Security	Code only
Keypad Code	201
Clinician Code	997
Admin Code	921
Manual Programming Security	Clinician Code
Continuous Mode Delivery Settings Hard and Soft Limits	(See <i>Manual Mode Initial Delivery Hard and Soft Limits</i> , on page 146)

Manual Mode Initial Settings

Manual Mode Initial Delivery Settings	
Therapy	Default Setting
All Therapies	
Reservoir Vol.	0 mL
PCA	
Continuous Rate	0 mL/hr
PCA Dose	0 mL
PCA Lockout	1 Hrs 0 Min
KVO Rate	0.1 mL/hr
Give Clinician Bolus	0 mL/hr
Continuous	
Continuous Rate	0.1 mL/hr
KVO Rate	0 mL/hr
Intermittent	
Dose Volume	0.1 mL
Dose Duration	2 Hrs 0 Min
Dose Cycle	24 Hrs 0 Min
Dose Rate	0.1 mL/hr
Next Dose	[current time]
KVO Rate	0 mL/hr
Step	
Infusion Volume	1 mL
Initial Rate	0.4 mL/hr
Rate Increment	0.4 mL/hr
Plateau Rate	0.4 mL/hr
Step Duration	30 Min
Infusion Duration	2 Hrs 30 Min
KVO Rate	0 mL/hr
Taper	
Infusion Volume	24 mL
Taper Up	0 Min
Taper Down	0 Min
Infusion Duration	24 Hrs 0 Min
Plateau Rate	1 mL/hr
KVO Rate	1 mL/hr

Manual Mode Initial Delivery Hard and Soft Limits				
Therapy	Default Settings			
PCA				
Continuous Rate	Hard Max: Soft Max:	100 mL/hr 100 mL/hr	Soft Min: Hard Min:	0 mL/hr 0 mL/hr
PCA Dose	Hard Max: Soft Max:	50 mL/hr 50 mL/hr	Soft Min: Hard Min:	0 mL/hr 0 mL/hr
PCA Lockout	Hard Max: Soft Max:	24 Hrs 0 Min 24 Hrs 0 Min	Soft Min: Hard Min:	24 Hrs 0 Min 24 Hrs 0 Min
Delivery Limit Method	Not in use			
Max Delivery Rate	125 mL/hr			
Clinician Bolus	Hard Max: Soft Max:	50 mL/hr 50 mL/hr	Soft Min: Hard Min:	0 mL/hr 0 mL/hr
Continuous				
Continuous Rate	Hard Max: Soft Max:	500 mL/hr 500 mL/hr	Soft Min: Hard Min:	0.1 mL/hr 0.1 mL/hr
Intermittent				
Dose Volume	Hard Max: Soft Max:	1,000 mL/hr 1,000 mL/hr	Soft Min: Hard Min:	0.1 mL/hr 0.1 mL/hr
Dose Duration	Hard Max: Soft Max:	24 Hrs 0 Min 24 Hrs 0 Min	Soft Min: Hard Min:	24 Hrs 0 Min 24 Hrs 0 Min
Dose Cycle	Hard Max: Soft Max:	96 Hrs 0 Min 96 Hrs 0 Min	Soft Min: Hard Min:	96 Hrs 0 Min 96 Hrs 0 Min
Step				
Initial Rate	Hard Max: Soft Max:	499 mL/hr 499 mL/h	Soft Min: Hard Min:	0.4 mL/hr 0.4 mL/hr
Rate Increment	Hard Max: Soft Max:	499 mL/hr 499 mL/h	Soft Min: Hard Min:	0.4 mL/hr 0.4 mL/hr
Plateau Rate	Hard Max: Soft Max:	500 mL/hr 500 mL/h	Soft Min: Hard Min:	0.4 mL/hr 0.4 mL/hr
Taper				
Infusion Volume	Hard Max: Soft Max:	9,990 mL 9,990 mL	Soft Min: Hard Min:	1 mL/hr 1 mL/hr
Max Plateau Rate	500 mL/hr			

Page intentionally blank

Accuracy Test Results

In this device, as with all infusion pumps, the motion of the pumping mechanism and variations in individual disposables cause short-term fluctuations in rate accuracy. The following curves show typical performance of the pump system in two ways:

1. A flow versus time graph during the stabilization period (start-up curves).
2. The accuracy of fluid delivery of particular time periods, or observation windows, is measured (trumpet curves).

Per the IEC 60601-2-24 standard, the stabilization period (T1) is summarized in the start-up curve, which displays flow rate versus time from the start of the infusion to the beginning of the analysis period (T2). The trumpet curve is derived from the last 100 sample intervals (analysis period) that occurs after the stabilization period.

Over long observation windows, short term fluctuations have minimal effect on accuracy as represented by the flat part of the curve. As the observation window is reduced, short term fluctuations have an increasing effect as represented by the “mouth” of the trumpet. Being aware of system accuracy over various observation windows may be of interest when certain drugs are being administered. Short term fluctuations in rate accuracy may have clinical impact depending on the half-life of the drug being infused, both the trumpet curve and drug half-life should be taken into consideration.

Start-up curves over the stabilization period T(1)

Flow rate (10 mL/hr) CADD® administration set with Flow Stop

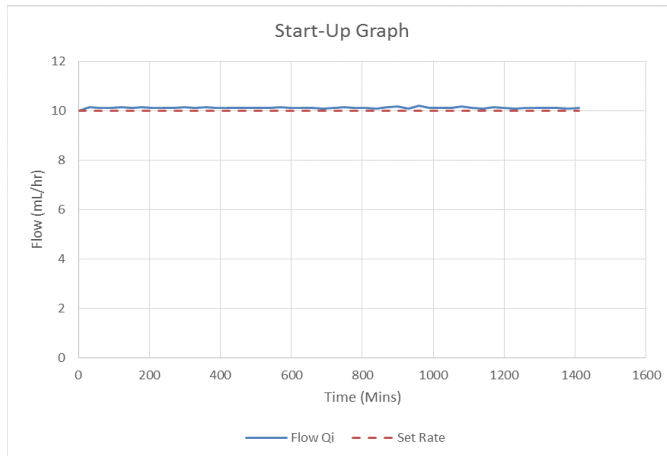

Flow rate (150 mL/hr) CADD® administration set with Flow Stop

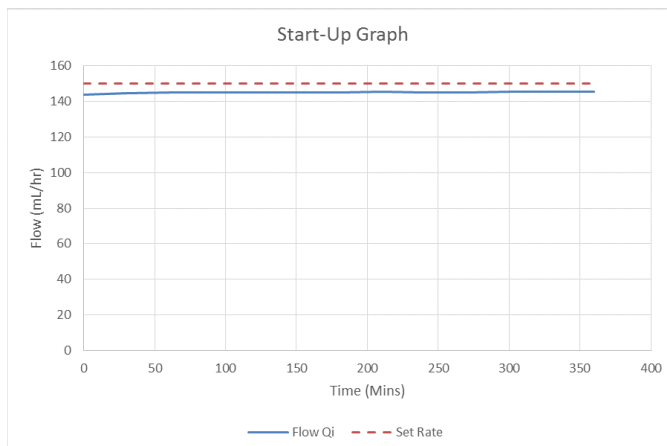

Flow rate (150 mL/hr) CADD® high volume administration set with Flow Stop

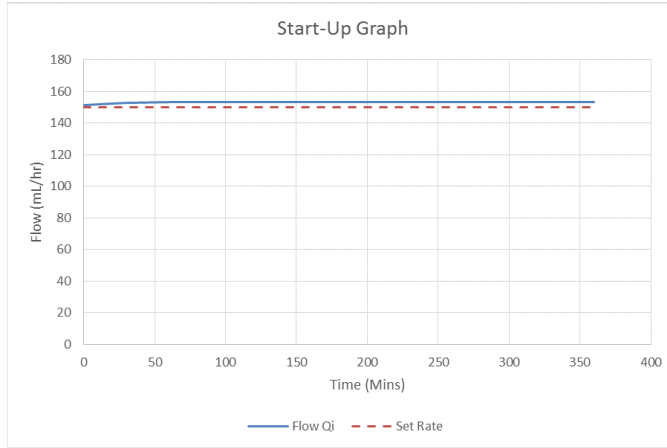

Trumpet curves over the analysis period T(2)

Flow rate (10 mL/hr) CADD® administration set with Flow Stop

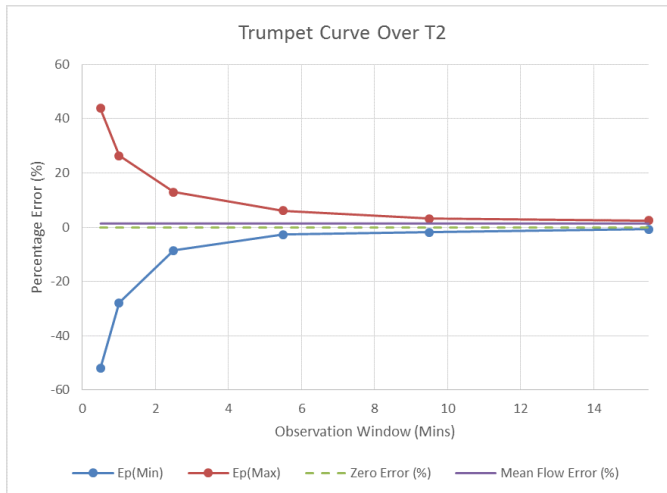

Flow rate (150 mL/hr) CADD® administration set with Flow Stop

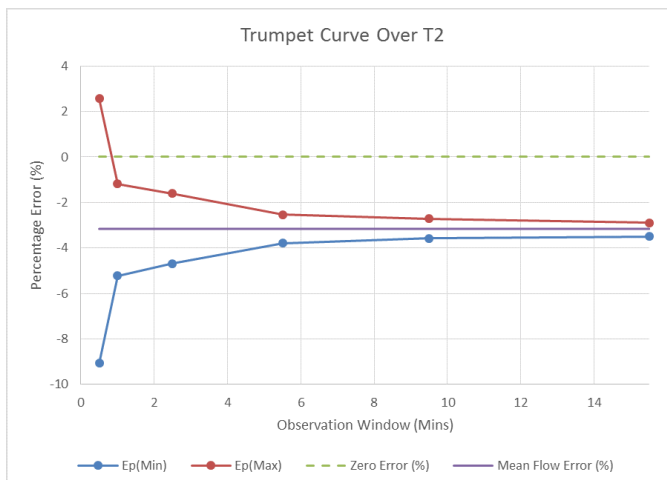

Flow rate (150 mL/hr) CADD® high volume administration set with Flow Stop

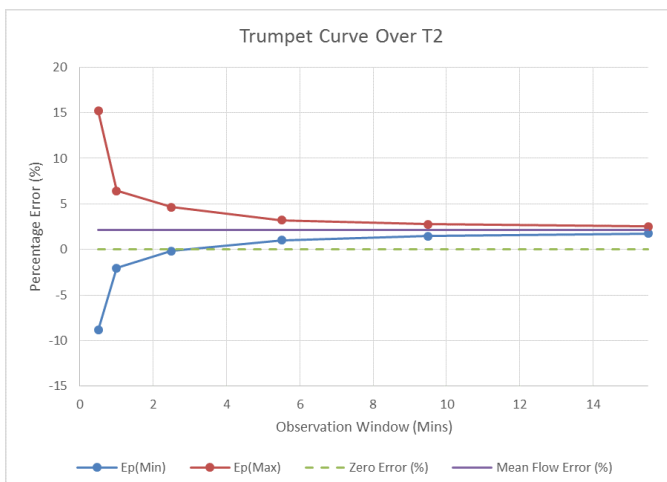

Limited Warranty

Smiths Medical ASD, Inc. (the “Manufacturer”) warrants to the Original Purchaser that the CADD®-Solis Ambulatory Infusion Pump (“Pump”), not including accessories, shall be free from defects in materials and workmanship under normal use, if used in accordance with this Operator’s Manual, for a period of two years from the actual date of sale to the Original Purchaser. THERE ARE NO OTHER WARRANTIES.

This warranty does not cover normal wear and tear and maintenance items, and specifically excludes batteries, administration sets, extension sets or any other accessory items or equipment used with the Pump.

Subject to the conditions of and upon compliance with this Limited Warranty, the Manufacturer will repair or replace at its option without charge (except for a minimal charge for postage and handling) any Pump (not including accessories) which is defective if a claim is made during such two-year period.

The following conditions, procedures, and limitations apply to the Manufacturer’s obligation under this warranty:

- A. Parties Covered by this Warranty:** This warranty extends only to the Original Purchaser of the Pump. This warranty does not extend to subsequent purchasers. The Original Purchaser may be a patient, medical personnel, a hospital, or institution which purchases the Pump for treatment of patients. The Original Purchaser should retain the invoice or sales receipt as proof as to the actual date of purchase.
- B. Warranty Performance Procedure:** Notice of the claimed defect must be made in writing or by telephone to the Manufacturer as follows: Customer Service Department, **Smiths Medical ASD, Inc.**, 6000 Nathan Lane North, Minneapolis, MN 55442, USA +1 614 210 7300 (US/CA) or **Smiths Medical Czech Republic a. s.**, Olomoucká 306, Hranice 1 - Město, 753 01 Hranice, Czech Republic, +44 (0)1233 722100. Notice to the Manufacturer must include date of purchase, model and serial number, and a description of the claimed defect in sufficient detail to allow the Manufacturer to determine and facilitate any repairs which may be necessary. Authorization must be obtained prior to returning the Pump. If authorized, the Pump must be properly and carefully packaged and returned to the Manufacturer, postage prepaid. Any loss or damage during shipment is at the risk of the sender.
- C. Conditions of Warranty:** The warranty is void if the Pump has been 1) repaired by someone other than the Manufacturer or its authorized agent; 2) altered so that its stability or reliability is affected; 3) misused; or, 4) damaged by negligence or accident. Misuse includes, but is not limited to, use not in compliance with the Operator’s Manual or use with nonapproved accessories. The Pump is a sealed unit, and the fact that the seal has been broken will be considered conclusive evidence that the Pump has been altered or misused. Removal or damage to the Pump’s serial number will invalidate this warranty.
- D. Limitations and Exclusions:** Repair or replacement of the Pump or any component part thereof is the EXCLUSIVE remedy offered by the Manufacturer. The following exclusions and limitations shall apply:
1. No agent, representative, or employee of the Manufacturer has authority to bind the Manufacturer to any representation or warranty, expressed or implied.
 2. THERE IS NO WARRANTY OF MERCHANTABILITY OR FITNESS OR USE OF THE PUMP FOR ANY PARTICULAR PURPOSE.
 3. The Pump can only be used under the supervision of medical personnel whose skill and judgment determine the suitability of the Pump for any particular medical treatment.
 4. All recommendations, information, and descriptive literature supplied by the Manufacturer or its agents are believed to be accurate and reliable, but do not constitute warranties.
- E. Computer Program License:**
1. The Pump is intended to be used in conjunction with a particular Licensed Computer Program supplied by Manufacturer and use of any other program or unauthorized modification of a Licensed Computer Program shall void Manufacturer’s warranty as set forth above.
 2. The Original Purchaser and any users authorized by the Original Purchaser are hereby granted a nonexclusive, nontransferable license to use the Licensed Computer Program only in conjunction with the single Pump supplied by Manufacturer. The Licensed Computer Program is supplied only in machine-readable object code form and is based upon Manufacturer’s proprietary confidential information. No rights are granted under this license or otherwise to decompile, produce humanly readable copies of, reverse engineer, modify or create any derivative works based upon the Licensed Computer Program.
 3. All other terms and conditions of this Limited Warranty shall apply to the Licensed Computer Program.

The Manufacturer disclaims responsibility for the suitability of the Pump for any particular medical treatment or for any medical complications resulting from the use of the Pump. The Manufacturer shall not be responsible for any incidental damages or consequential damages to property, loss of profits, or loss of use caused by any defect or malfunction of the Pump.

This warranty gives the Original Purchaser specific legal rights, and the Original Purchaser may have other legal rights which may vary from state to state.

Index

A

- AC adapter 16
- Accessories 16
- Accuracy 133, 134
- AC power jack 13
- Admin code 20, 26, 136
- Advanced tasks 143, 144
 - Air and occlusion settings 105
 - Alarm settings 108
 - Delivery hard and soft limits 35
 - Give clinician bolus 45
 - Menu maps 143, 144
 - Patient permissions 103
 - Reset to factory settings 112
 - Security settings 20, 24
 - Start new patient 29
 - Start new protocol same patient 29
 - Step down 70
 - Step up 69
- Air and occlusion settings 105, 144
 - Air detector on/off 105
 - Air detector sensitivity 106, 136
 - Downstream sensor sensitivity 107, 136
 - Upstream sensor on/off 106
- Air detector 15, 123
 - On/Off 105
 - Sensitivity 106, 134
- Alarms and messages 113
 - Alphabetical list 116
 - Help screens 114
 - High priority alarm 113, 128
 - Informational message 114
 - Low priority alarm 114
 - Medium priority alarm 113
 - System fault alarm 113
 - Troubleshooting 116
- Alarm settings 108, 144
 - Infusion alerts on/off 108
 - PM interval 111
 - PM reminder 111
 - PM reminder on/off 110
 - Pump stopped alarm type 108
 - Reservoir empty alarm type 110
 - Reservoir low alarm type 109
 - Reservoir low trip point 109
- Alarm volume 92
- Amber indicator light 13, 14, 82, 89, 113
- Analgesics 10
- Anesthetics 10
- Autolock 23

B

- Backlight intensity 92
- Batteries 80, 132
 - AA batteries 15, 18, 80, 81
 - AC adapter 13, 16, 80
 - Battery compartment 13, 15, 81
 - Battery life 130
 - Battery status 18, 129
 - Installing batteries 81
 - Rechargeable battery pack 15, 16, 80, 81
 - Symbols 11, 12, 18

C

- CADD-Solis Medication Safety Software 19, 24, 29, 35, 36, 82, 102
- Cassette 13, 83
 - Attach a cassette 84, 90
 - Remove a cassette 83
- Cassette/Keypad lock 11, 13, 15
- Cassette latch 13, 15
- Cautions 7
- Cleaning and Disinfecting the Pump and Accessories 123
- Clinician bolus 45, 48
- Clinician code 20, 26, 136
- Color 19
 - Amber 13, 14, 20, 36, 82, 89, 113
 - Blue 13, 15, 19, 20, 53, 82, 114
 - Gray 19, 39, 49, 53, 61, 71, 82
 - Green 13, 14, 20, 36, 39, 49, 53, 61, 71, 82, 88
 - Olive 19, 61
 - Purple 19, 39
 - Red 20, 39, 49, 53, 61, 71, 89, 113
 - Yellow 19
- Continuous rate 40, 43, 49, 51
- Continuous therapy 49
 - Continuous rate 49
 - Default values, manual program 31
 - Delayed start 33
 - Delivery specifications 137
 - Home screen 49
 - KVO rate 49
 - Programming example 50
 - Reservoir vol. 50
 - Set delayed start 33
 - Start time 50
- Contraindications 3, 10
- Counters, given and PCA dose 99
- Current date 96
- Current time 18, 95
- Current value, delivery limit 35

D

Date, current 96
 Date format 97, 136
 Daylight savings time 97
 Default factory settings 145
 Delayed start 33, 88, 136
 Delayed start security on/off 104
 Delivery hard and soft limits 35, 144, 147
 Delivery history and pie chart 100
 Delivery limits 31, 35, 36, 41, 144, 147
 Delivery log 100
 Delivery settings 36, 142, 146

- Continuous rate 40, 49
- Delivery limit 41
- Dose cycle 54
- Dose duration 54
- Dose rate 54
- Dose volume 54
- Edit delivery settings 37
- Infusion duration 63, 72
- Infusion volume 62, 72
- Initial rate 62
- KVO rate 41, 49, 55, 63, 73
- Max doses/hr 41
- Next dose 54
- PCA dose 40
- PCA lockout 40
- Plateau rate 62, 72
- Rate increment 62
- Reservoir vol. 41, 50, 55, 63, 73
- Review pump settings 38
- Start time 41, 50, 63, 73
- Step duration 62
- Taper down 72
- Taper up 72
- View delivery settings 37

 Device information 102
 Disinfecting the pump and accessories 123
 Display and backlight 14, 17, 18
 Display and sound settings 92, 142

- Alarm volume 92
- Backlight intensity 92
- Key beep on/off 94
- Numeric format 94
- Sound theme 93

 Dose cycle 54, 57
 Dose duration 54, 57
 Dose rate 54, 57
 Dose volume 54, 56
 Downstream occlusion sensor 15

- Sensitivity 107, 136

 Drug 18, 28

E

Edit delivery settings 37
 Epidural administration 10
 Event log 101
 Examples *See* Programming examples

F

Factory settings, reset 112

G

Given and PCA dose counters 99
 Green indicator light 13, 14, 82, 88

H

Hard delivery limits 35, 147
 Help

- Screens 114
- Technical assistance 3

 High priority alarm 113, 128
 Home screen 18, 39, 49, 53, 61, 71

I

Indications 10
 Informational message 114
 Infusion alerts on/off 108
 Infusion duration 63, 67, 72, 76
 Infusion volume 62, 65, 72, 75
 Initial rate 62, 65
 Intermittent therapy 53

- Default values, manual program 31
- Delivery specifications 137
- Dose cycle 54
- Dose duration 54
- Dose rate 54
- Dose volume 54
- Home screen 53
- KVO rate 55
- Nest dose start time 34
- Next dose 54
- Programming example 55
- Reservoir vol. 55
- Reset a cycle 60
- Restart a dose 60
- Set delayed start 33
- Stop the pump during an infusion 60

K

Key *See* Pump key
 Key beep on/off 94
 Keypad 11, 13, 14
 Keypad code 20, 25, 136
 Keypad security 25

KVO rate 41, 44, 49, 52, 55, 58, 63, 67, 73, 77

L

Last error code 102
 Latch 13, 15
 LCD *See* Display
 Libraries 28, 29
 Lights 13, 14
 Continuously on 14, 113
 Flashing 14, 82, 88, 89
 Limits *See* Delivery limits
 Lock 15, 16, 17, 18, 23
 Log
 Delivery 100
 Event 101
 Low priority alarm 114

M

Magnetic resonance imaging *See* MRI and radiation
 Manual mode, initial settings 146, 147
 Manual programming 30
 Protocol default values 31
 Security 27
 Max doses/hr 41, 44
 Medication Safety Software *See* CADD-Solis
 Medication Safety Software
 Medium priority alarm 113
 Menu maps 142
 Menu screen 18
 Messages 113
 Alphabetical list 116
 Help screens 114
 Informational message 114
 Troubleshooting 116
 MRI and radiation 124

N

New patient 29
 New protocol same patient 29
 New protocol selection 28
 Next dose 54, 58
 Next dose start time 34
 Numeric format 94

O

Occlusion and air settings 105, 144
 Air detector on/off 105
 Air detector sensitivity 106, 136
 Downstream sensor sensitivity 136
 Upstream sensor on/off 106
 Occlusion sensor
 Downstream 15
 Upstream 15

P

Patient permissions 103, 144
 Delayed start security on/off 104
 Priming security on/off 104
 PCA dose , 11, 40, 43, 47
 PCA dose counters 99
 PCA dose graph 99
 PCA lockout 40, 44
 PCA therapy 39
 Clinician bolus 45, 48
 Continuous rate 40, 43
 Default values, manual program 31
 Delayed start 33
 Delivery limit 41
 Delivery specifications 137
 Home screen 39
 KVO rate 41
 Max doses/hr 41
 PCA dose 40, 43, 47, 48
 PCA lockout 40, 44
 Programming example 42
 Programming screens 40
 Remote dose cord 16, 40, 47
 Reservoir vol. 41
 Scroll ranges 126
 Set delayed start 33
 Start time 41
 Stop clinician bolus 48
 Stop PCA dose 48
 Pie chart and delivery history 100
 Plateau rate 62, 66, 72, 77
 PM *See* Preventive maintenance (PM)
 Power down (off) 82
 Power jack 13, 15
 Power light 13
 Power switch 11, 13
 Power up (on) 82
 Preventive maintenance (PM)
 PM interval 111
 PM reminder 111, 136
 PM reminder on/off 110
 Prime tubing 86, 135
 Priming security on/off 104
 Programming examples
 Continuous therapy 50
 Intermittent therapy 55
 PCA therapy 42
 Step therapy 64
 Taper therapy 74
 Programming screens
 Continuous therapy 49
 Intermittent therapy 54
 PCA therapy 40
 Step therapy 62
 Taper therapy 72
 Programming the pump 28

Manual programming 30
 Protocol selection from a library 29
 Single protocol download 28
 Protocol library summary 101
 Protocols 28
 Libraries 28, 101
 Manual programming 30
 New protocol selection 28
 Protocol selection from a library 29
 Single protocol download 28
 Pump key 17, 24, 25
 Pump screen 18
 Pump stopped alarm type 108

Q

Qualifier 18, 28

R

Radiation and MRI 124
 Rate increment 62, 66
 Rechargeable battery pack 12, 15, 16, 80, 81, 82, 131
 Remote dose cord 14, 16, 40, 47
 Remote dose cord jack 13, 15
 Reports 98, 143
 Delivery history and pie chart 100
 Delivery log 100
 Device information 102
 Event log 101
 Given and PCA dose counters 99
 PCA dose graph 99
 Protocol library summary 101
 Total given 98
 Reservoir empty alarm type 110
 Reservoir low alarm type 109
 Reservoir low trip point 109, 136
 Reservoir volume 41, 45, 50, 52, 55, 59, 63, 68, 73, 77, 90, 136
 Reset reservoir volume 90
 Reset to factory settings 112
 Review pump settings 32, 38, 42, 51, 56, 64, 74

S

Same patient, new protocol 29
 Screens and display 18
 Security codes *See* Security settings
 Security settings 20, 144
 Admin code 20, 26
 Autolock 23
 Clinician code 20, 26
 Customized settings 23, 24
 Entering security codes 23

Keypad code 20, 25
 Keypad security 25
 Manual programming 27
 Tables 21, 22
 Select drug 30, 42, 51, 56, 64, 74
 Select qualifier 29, 32, 42, 50, 55, 64, 74
 Select therapy 29, 32, 42, 50, 55, 64, 74
 Serial number 102
 Set delayed start 33
 Set next dose start time 34
 Single protocol download 28
 Soft delivery limits 35, 147
 Soft keys 11, 14
 Software version 102
 Sound theme 93
 Specifications 128
 General pump specifications 128
 Start new patient 29, 32
 Start new protocol same patient 29
 Start the pump
 Daily infusion 78
 Delayed start 88
 Give a clinician bolus 45
 Next dose start time 88
 Power up 82
 Reset a cycle or infusion 60, 69
 Restart a dose or infusion 60, 69
 Start an infusion 69
 Start a PCA dose 47
 stop/start button 11
 Start time 41, 50, 63, 73
 Step down 70
 Step duration 62, 67
 Step therapy 61
 Default values, manual program 31
 Delayed start 33
 Delivery specifications 138
 Home screen 61
 Infusion duration 63
 Infusion volume 62
 Initial rate 62
 KVO rate 63
 Plateau rate 62
 Programming example 64
 Rate increment 62
 Reservoir vol. 63
 Restarting the pump during an infusion 69
 Set delayed start 33
 Starting each infusion 69
 Start time 63
 Step down 70
 Step duration 62
 Step up 69
 Step up 69
 Stopping during an infusion 69
 Stop the pump 89

Power down 80
 Stop a clinician bolus 46, 87
 Stop a PCA dose 46, 87
 stop/start button 10
 Stop the pump during an infusion 58
 Taper down before stopping 77, 87
 Subarachnoid administration 9
 Symbols 11
 Home screen 16, 37, 47, 51, 59, 69
 System fault alarm 111

T

Taper down 70, 74, 77
 Taper down now 77
 Taper therapy 69
 Default values, manual program 29
 Delayed start 31
 Delivery specifications 133
 Home screen 69
 Infusion duration 70
 Infusion volume 70
 KVO rate 71
 Plateau rate 70
 Programming example 72
 Reservoir vol. 71
 Set delayed start 31
 Start time 71
 Taper down 70
 Taper up 70
 Taper up 70, 73
 Tasks menu 89
 Change time and date 93
 Display and sound settings 90
 Menu maps 137
 Next dose start time 32
 Prime tubing 84
 Reset reservoir volume 88
 Set delayed start 31
 Set next dose start time 32
 Taper down now 77
 View delivery settings 35
 View reports 96
 Therapy 16, 26
 Time and date 93, 137
 Current date 94
 Current time 17, 93
 Date format 95, 131
 Daylight savings time 95
 Military time 124
 Time format 94, 131
 Total given 96
 Troubleshooting 113

U

Ultrasound 121
 Unlock 21, 22
 Upstream occlusion sensor 14
 On/Off 104
 USB port 12, 14

V

View delivery settings 35
 Volume
 Alarm 90, 131
 Reservoir 39, 43, 48, 50, 53, 57, 61, 66, 71,
 75, 88, 131

W

Warnings 3

Page intentionally blank

CADD[®]

 Manufacturer:
Smiths Medical ASD, Inc.
6000 Nathan Lane North
Minneapolis, MN 55442 USA
Tel: 1 800 258 5361 (US/CA)
Tel: +1 614 210 7300

Rx **CE**
ONLY **2797**

 European Representative:
Smiths Medical Czech Republic a. s.
Olomoucká 306, Hranice 1 - Město,
753 01 Hranice, Czech Republic
Tel: +44 (0)1233 722100

www.smiths-medical.com

CADD-Solis, CADD, the CADD design mark, and the Smiths Medical design mark are trademarks of Smiths Medical. The symbol ® indicates the trademark is registered in the U.S. Patent and Trademark Office and certain other countries. All other names and marks mentioned are trade names, trademarks, or service marks of their respective owners.

© 2017, 2018, 2019, 2023 Smiths Medical. All rights reserved.